

BARINGO COUNTY GOVERNMENT

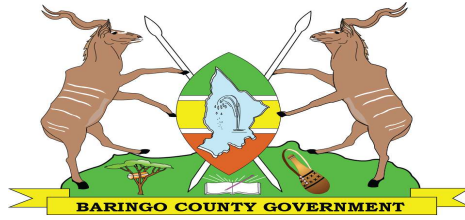

MINISTRY OF TRANSPORT AND INFRASTRUCTURE

Tender Document

TENDER NO. BCG/TNR/25/2017/2018

**TENDER NAME: – PROPOSED
UPGRADING OF KAPROGONYA
ROAD**

**INSTRUCTION TO TENDERERS
CONDITIONS OF CONTRACT
STANDARD FORMS
BILLS OF QUANTITIES**

FINANCIAL YEAR 2017/2018

BARINGO COUNTY GOVERNMENT

P. O. Box 53 - 30400

KABARNET

Tel:053 22115

CLOSING DATE: 15TH DECEMBER, 2017

TIME: 12.00 NOON (EAST AFRICAN TIME)

INSTRUCTIONS TO TENDERERS

SECTION A

- A. Complete set of tender documents can be obtained from Supply Chain Management Unit (at the Office of the Governor) upon payment of non-refundable fees of **Kshs. 1,000/= (Kenya Shillings One Thousand Only)** in cash or Bankers cheque payable to **The Governor, Baringo County Government**.
- B. Tenderers shall be required to furnish the procuring Entity with the following information as a minimum criterion for submission of a bid for this works, supported by the relevant documents: -
- (1.) Proof of works of similar magnitude and complexity undertaken in the last five years.
 - (2.) Adequate equipment and key personnel for the specified types of works.
 - (3.) Sound financial standing and adequate access to bank credit line.
 - (4.) Litigation History of the Company (both court and arbitration cases, if any).
 - (5.) Tender Form and Confidential Business Questionnaire dully filled and signed by an authorized person.
 - (6.) Proof of Registration as a Contractor eligible to undertake Civil Works (Road Works) with the relevant Authority (i.e. NCA 6 and Above).
 - (7.) PIN, VAT and Tax Compliance Certificates.
 - (8.) Evidence of the on-going projects regardless of the total value of the outstanding works;
 - (9.) Power of attorney for the person authorized to sign on behalf of the company;
 - (10.) A copy of CR12
- C. The tenderer shall furnish, as part of the tender, a Tender Security for a sum of Kshs. Fifty thousand only (50,000.00). This shall be in the form of a bank draft , bank guarantee or Insurance from an established and reputable bank or insurance firm approved by the Employer and PPOA in the format provided in the Tender Documents to remain in force for a period of One Hundred and Fifty (150) days from the closing date of the tender.
- D. A successful Tenderer (Candidate) upon award of contract shall be required to furnish the Procuring Entity with a Performance Guarantee (Security) of **5% (Five Percent) of the Contract Sum** before signing the Contract Agreement and commencement of the works.
- E. Prices quoted should be net inclusive of all taxes and delivery must be in Kenya Shillings and shall remain valid for **One Hundred and Twenty (120) days** from the closing date of the tender.
- F. A prospective tenderer requiring any clarification of the tender documents may notify the Employer in writing or by cable, telex, facsimile or e-mail at the address given here-below. The Employer will only respond to requests for clarification received earlier than seven days prior to the deadline for submission of tenders. Copies of the Employer's response will be forwarded to all persons issued with tendering documents, including a description of the inquiry, but without identifying its source.
- Address for Clarifications: THE DIRECTOR-SUPPLY CHAIN MANAGEMENT,
COUNTY GOVERNMENT OF BARINGO,
P.O. BOX 53-30400
KABARNET.
- G. Completed tender documents (Original and Copy) are to be enclosed in plain sealed envelopes marked with tender reference number and be deposited in the **Tender Box at the Ground Floor of the Office of the Governor**,

Baringo County Government (along Hospital Road) or be addressed to The Office of the Governor, Baringo County Government, P. O. Box 53 - 30400, Kabarnet so as to be received on or before Friday 15th December, 2017 12.00 noon (East African Time).

- H.** Tenders will be opened publicly immediately thereafter in the presence of the Candidates or their representatives who choose to attend at **Baringo County Government Offices (along Hospital Road), Kabarnet.**
- I.** Please confirm receipt of this letter immediately in writing by mail, email, cable/facsimile or telex.

FORM OF TENDER

TO: _____[Name of Employer] _____[Date]
_____ [Name of Contract]

Dear Sir,

1. In accordance with the Conditions of Contract, Specifications, Drawings and Bills of Quantities for the execution of the above named Works, we, the undersigned offer to construct, install and complete such Works and remedy any defects therein for the sum of
Kshs. _____ [Amount in figures] Kenya
Shillings _____
_____ [Amount in words]

2. We undertake, if our tender is accepted, to commence the Works as soon as is reasonably possible after the receipt of the Project Manager's notice to commence, and to complete the whole of the Works comprised in the Contract within the time stated in the Appendix to Conditions of Contract.

3. We agree to abide by this tender until _____ [Insert date], and it shall remain binding upon us and may be accepted at any time before that date.

4. Unless and until a formal Agreement is prepared and executed this tender together with your written acceptance thereof, shall constitute a binding Contract between us.

5. We understand that you are not bound to accept the lowest or any tender you may receive.

Dated this _____ day of _____ 20_____

Signature _____ in the capacity of _____

duly authorized to sign tenders for and on behalf of
_____ [Name of Tenderer]

of _____ [Address of Tenderer]

Witness; Name _____

Address _____

Signature _____

Date _____

FORM OF AGREEMENT

THIS AGREEMENT, made the _____ day of _____ 20 _____
between _____ of [or whose registered office is
situated at] _____
(hereinafter called “the Employer”) of the one part AND
_____ of [or whose registered office is
situated at] _____
(hereinafter called “the Contractor”) of the other part.

WHEREAS THE Employer is desirous that the Contractor executes

_____ (name and identification number of Contract) (hereinafter called “the Works”) located
at _____ [Place/location of the Works] and the Employer has accepted
the tender submitted by the Contractor for the execution and completion of such Works and the
remedying of any defects therein for the Contract Price of
Kshs _____ [Amount in figures], Kenya
Shillings _____ [Amount in words].

NOW THIS AGREEMENT WITNESSETH as follows:

1. In this Agreement, words and expressions shall have the same meanings as are respectively assigned to them in the Conditions of Contract hereinafter referred to.
2. The following documents shall be deemed to form and shall be read and construed as part of this Agreement i.e.
 - (i) Letter of Acceptance
 - (ii) Form of Tender
 - (iii) Conditions of Contract Part I
 - (iv) Conditions of Contract Part II and Appendix to Conditions of Contract
 - (v) Specifications
 - (vi) Drawings
 - (vii) Priced Bills of Quantities
3. In consideration of the payments to be made by the Employer to the Contractor as hereinafter mentioned, the Contractor hereby covenants with the Employer to execute and complete the Works and remedy any defects therein in conformity in all respects with the provisions of the Contract.
4. The Employer hereby covenants to pay the Contractor in consideration of the execution and completion of the Works and the remedying of defects therein, the Contract Price or such other sum as may become payable under the provisions of the Contract at the times and in the manner prescribed by the Contract.

IN WITNESS whereof the parties thereto have caused this Agreement to be executed the day and year first before written.

The common Seal of _____

Was hereunto affixed in the presence of _____

Signed Sealed, and Delivered by the said _____

Binding Signature of Employer _____

Binding Signature of Contractor _____

In the presence of (i) Name _____

Address _____

Signature _____

Signed (i) Name _____

Address _____

Signature _____

Signed (i) Name _____

Address _____

Signature _____

Counter signed (i) Name _____

Address _____

Signature _____

FORM OF TENDER SECURITY

WHEREAS(hereinafter called “the Tenderer”) has submitted his tender dated for the construction of (name of Contract)

KNOW ALL PEOPLE by these presents that WE having our registered office at(hereinafter called “the Bank”), are bound unto(hereinafter called “the Employer”) in the sum of Kshs..... for which payment well and truly to be made to the said Employer, the Bank binds itself, its successors and assigns by these presents sealed with the Common Seal of the said Bank this Day of20.....

THE CONDITIONS of this obligation are:

- 1. If after tender opening the tenderer withdraws his tender during the period of tender validity specified in the instructions to tenderers
Or
2. If the tenderer, having been notified of the acceptance of his tender by the Employer during the period of tender validity:
(a) fails or refuses to execute the form of Agreement in accordance with the Instructions to Tenderers, if required; or
(b) fails or refuses to furnish the Performance Security, in accordance with the Instructions to Tenderers;

We undertake to pay to the Employer up to the above amount upon receipt of his first written demand, without the Employer having to substantiate his demand, provided that in his demand the Employer will note that the amount claimed by him is due to him, owing to the occurrence of one or both of the two conditions, specifying the occurred condition or conditions.

This guarantee will remain in force up to and including thirty (30) days after the period of tender validity, and any demand in respect thereof should reach the Bank not later than the said date.

[date] [signature of the Bank]
[witness] [seal]

PERFORMANCE BANK GUARANTEE

To: _____(Name of Employer) _____(Date)
_____(Address of Employer)

Dear Sir,

WHEREAS _____(hereinafter called “the Contractor”) has undertaken, in pursuance of Contract No. _____ dated _____ to execute _____ (hereinafter called “the Works”);

AND WHEREAS it has been stipulated by you in the said Contract that the Contractor shall furnish you with a Bank Guarantee by a recognised bank for the sum specified therein as security for compliance with his obligations in accordance with the Contract;

AND WHEREAS we have agreed to give the Contractor such a Bank Guarantee:

NOW THEREFORE we hereby affirm that we are the Guarantor and responsible to you, on behalf of the Contractor, up to a total of Kshs. _____ (amount of Guarantee in figures) Kenya Shillings _____ (amount of Guarantee in words), and we undertake to pay you, upon your first written demand and without cavil or argument, any sum or sums within the limits of Kenya Shillings _____ (amount of Guarantee in words) as aforesaid without your needing to prove or to show grounds or reasons for your demand for the sum specified therein.

We hereby waive the necessity of your demanding the said debt from the Contractor before presenting us with the demand.

We further agree that no change, addition or other modification of the terms of the Contract or of the Works to be performed thereunder or of any of the Contract documents which may be made between you and the Contractor shall in any way release us from any liability under this Guarantee, and we hereby waive notice of any change, addition, or modification.

This guarantee shall be valid until the date of issue of the Certificate of Completion.

SIGNATURE AND SEAL OF THE GUARANTOR _____

Name of Bank _____

Address _____

Date _____

BANK GUARANTEE FOR ADVANCE PAYMENT

To: _____ [name of Employer] _____ (Date)
_____ [address of Employer]

Gentlemen,

Ref: _____ [name of Contract]

In accordance with the provisions of the Conditions of Contract of the above-mentioned Contract, We, _____ [name and Address of Contractor] (hereinafter called "the Contractor") shall deposit with _____ [name of Employer] a bank guarantee to guarantee his proper and faithful performance under the said Contract in an amount of Kshs. _____ [amount of Guarantee in figures] Kenya Shillings _____ [amount of Guarantee in words].

We, _____ [bank or financial institution], as instructed by the Contractor, agree unconditionally and irrevocably to guarantee as primary obligator and not as Surety merely, the payment to _____ [name of Employer] on his first demand without whatsoever right of objection on our part and without his first claim to the Contractor, in the amount not exceeding Kshs _____ [amount of Guarantee in figures] Kenya Shillings _____ [amount of Guarantee in words], such amount to be reduced periodically by the amounts recovered by you from the proceeds of the Contract.

We further agree that no change or addition to or other modification of the terms of the Contract or of the Works to be performed thereunder or of any of the Contract documents which may be made between _____ [name of Employer] and the Contractor, shall in any way release us from any liability under this guarantee, and we hereby waive notice of any such change, addition or modification.

No drawing may be made by you under this guarantee until we have received notice in writing from you that an advance payment of the amount listed above has been paid to the Contractor pursuant to the Contract.

This guarantee shall remain valid and in full effect from the date of the advance payment under the Contract until _____ (name of Employer) receives full payment of the same amount from the Contract.

Yours faithfully,

Signature and Seal _____

Name of the Bank or financial institution _____

Address _____

Date _____

Witness: Name: _____

Address: _____

Signature: _____

Date: _____

APPENDIX TO FORM OF BID

This Appendix to Form of Agreement forms part of the Agreement.

(Note 1: with the exception of the items for which the Employer's requirements have been inserted, the Contractor shall complete the following information before submitting his offer.)

(Note 2: Form of Agreement is attached separately in the Contract File)

Item	Data
Time for Completion	90 days
Priority of Documents	The documents forming the Contract shall be interpreted in the following order of priority: the Contract Agreement and Appendix the Letter of Acceptance the Form of Tender the Conditions of Contract, Part II - Conditions of Particular Application (On Contract Document) the Conditions of Contract, Part I - General Conditions of Contract (On Contract Document) the Specifications (On Contract Document) the Drawings, (On Contract Document) the Priced Bill of Quantities
Law of Contract	Laws of the Republic of Kenya
Language	English
Provision of Site	On Commencement Date
Name and address of Employer	BARINGO COUNTY government Address: P.O. BOX 53-30400 KABARNET
Authorised Person	County Secretary, Baringo County Government P.O. Box 53-30400 KABARNET
Name and address of Engineer	Chief Officer, Ministry of Transport & Infrastructure Baringo County Government P.O. Box 53-30400 KABARNET
Name and Address of Engineer's Representative	County Engineer, Baringo County
Penalty to the Contractor for Employer paying workers on his behalf	10% of the amount paid to the workers.
Performance Security Amount	Required for works exceeding 5% of the Bid Sum
Bid Security Form	Kshs. 100,000.00 in the Invitation to Bid (Advert) As per the advert
Programme Time of Submission Form of Programme	Within 14 days of Commencement Date Bar chart*
Interval Updates	One (1) Month
Liquidated Damages Amount payable due to failure to	0.01% of Contract Price per Day to a limit of 1% of Contract Price.

Item	Data
complete	
Period of notifying defects	30 days calculated from the date stated in the notice under sub clause 8.2*
Form of Guarantee for Advance Payment	Bank Guarantee or Insurance Bond
Valuation of Works	Re-measurements with Bills of Quantities
Minimum Amount of Interim Payment	40% of the Contract Price excluding contingencies*
Currency of Payment	Kenya Shilling
Rate of Interest	Simple Interest at a rate of 2% above mean Base Lending Rate as issued by the Central Bank of Kenya.
Insurance	Required
Insurance The Works, materials plants & fees	Amount of Cover The Contract Price stated in the Agreement
Contractor's Equipment Third party injury to persons and damage to property	Full replacement cost. 10% per third party with number of occurrences unlimited.
Workers compensation	Contractor to indemnify employer against claims by those in employment of the contractor
Other cover	**
Arbitration Rules Appointing Authority Place of Arbitration	CAP 49 of the Laws of Kenya Chairman Chartered Institute of Arbitrators, Kenya Branch. Baringo County Headquarters

* Employer to fill as appropriate

** Contractor to fill as appropriate

Signature of Bidder Date

CONTENTS:	
INVITATION FOR TENDERS	1
INSTRUCTIONS TO TENDERERS.	9
1 GENERAL	9
TENDER DOCUMENTS	9
PREPARATION OF TENDERS	10
SUBMISSION OF TENDERS	10
TENDER OPENING	11
TENDER EVALUATION	11
AWARD OF CONTRACT	12

INSTRUCTIONS TO TENDERERS.

1

General

- 1.1 The Employer as defined in the Appendix to Conditions of Contract invites Tenders for the Works Contract as described in the Tender Documents.
- 1.2 Tenderers shall include the following information and documents with their Tenders, unless otherwise stated:
- a) Duly certified Certificate from Treasury for works in YW&D Category
 - b) evidence of access to lines of credit and availability of other financial resources
 - c) financial predictions for the current year and the two subsequent years, including the effect of known commitments
 - d) work commitments
 - e) current litigation information; and
 - f) availability of critical equipment
 - g) Registration with National Construction Authority for the applicable class valid at the date of tender submission
 - h) Certificate of Incorporation
 - i) PIN & VAT Registration Certificate
 - j) Valid current Tax compliance certificate valid as closing date
 - k) Address of the Principal place of Business (business permit)
 - l) Authority to seek references from Tenderer's Bankers
 - m) Authority for person signing the Tender
- 1.3 The Tenderer shall bear all costs associated with the preparation and submission of the Tender.
- 1.4 The Tenderer, at the Tenderer's own expense, responsibility and risk, shall visit and examine the Site of the Works and its surroundings, to obtain all information that may be necessary for the preparation of the Tender and entering into a Contract for the Works as defined in the Specifications (to be annexed during contract signing). Attendance at a pre-tender site meeting arranged by the Engineer shall be mandatory for the submission of an eligible tender. Each tenderer must dully complete a **Declaration of Tenderer's Knowledge of site**.

1.5 Eligible Tenderers

- a) The Invitation to Tender is open to all Tenderers qualified in accordance with to the conditions of the Press Advertisement or otherwise indicated by the Employer. Only Tenders from qualified Tenderers will be accepted.
- b) A Tenderer debarred from participating in Public Procurement by the Public Procurement Regulatory Authority shall not be eligible to submit a Tender.
- c) If the Employer has not undertaken the prequalification of Tenderers, all Tenderers shall include the information required to satisfy the qualification criteria as determined by the Employer.

2.

Tender Documents

- 2.1 The complete set of Tender documents comprises the documents listed below and any addenda issued in accordance with paragraph 2.4
- (i) Instructions to Tenderers
 - (ii) Form of Tender
 - (iii) Bills of Quantities/Schedule of Rates (whichever is applicable)
 - (iv) Other documents/materials required by the Employer to be completed and submitted in accordance with these Instructions and Conditions

- 2.2 The Tenderer shall examine all Instructions, Forms and Specifications (to be annexed during contract signing) in the Tender documents. Failure to furnish all information required by the Tender documents may result in the rejection of the Tender.
- 2.3 A Tenderer requiring any clarification of the Tender documents may notify the Employer in writing or by electronic means at the address indicated in the letter of Invitation to Tender. The Employer shall respond to any request for clarification received earlier than seven days prior to the deadline for submission of Tenders. Copies of the Employer's response will be forwarded to all persons issued with Tender documents, including a description of the inquiry, but without identifying its source.
- 2.4 Before the deadline for submission of Tenders, the Employer may modify the Tender documents by issuing addenda. Any addenda thus issued shall be part of the Tender documents and shall be communicated in writing or by electronic means to all Tenderers. Tenderers shall acknowledge receipt of each addendum in writing to the Employer.
- 2.5 The Employer may extend, as necessary, the deadline for submission of Tenders in accordance with paragraph 4.5 below, to take account of any addenda issued.
- 2.6 The timescale given for the Completion of Works has been based on the optimum use of labour-based construction.

3. Preparation of Tenders

- 3.1 All documents relating to the Tender and any correspondence shall be in the English Language.
- 3.2 The Tender submitted shall comprise the following:-
- (a) The Form of Tender;
 - (b) Tender Security (as instructed in the Form of Invitation to Tender)
 - (c) Standard Forms and Schedules of Supplementary Information,
 - (d) Priced Bill of Quantities initialed on each page, or Schedule of Rates (whichever is applicable)
 - (e) Any other documents/materials required by the Employer to be completed and submitted by Tenderers.
- 3.3 The Tenderer shall fill in rates and prices for all items of the Works described in the Bill of Quantities/Schedule of Rates. **Items for which no rate or price is entered shall be deemed covered by the other rates and prices in the Bill of Quantities/Schedule of Rates.**
- 3.4 The unit rates and prices shall be in Kenya Shillings.
- 3.5 Tenders shall remain valid for a period of **a period of Ninety (90) days from the Commencement Date**. However, the Employer may request the Tenderers to extend the period of validity for a specified additional period. Such a request and the Tenderers' responses shall be made in writing.
- 3.6 The Tenderer shall prepare one original of the Tender documents as described in these Instructions to Tenderers, and one copies if required by the Invitation to Tender.
- 3.7 The original shall be **typed** or **written in indelible ink** and shall be signed by a person or persons duly authorised to sign on behalf of the Tenderer who shall initial all pages of the Tender where alterations or additions have been made.

4. Submission of Tenders

- 4.1 The Tender duly **bound, completed and sealed** in an envelope shall:-
- (a) be addressed to the Employer at the address provided in the Invitation to Tender;
 - (b) bear the name and identification number of the Tenderer as defined in the Invitation to Tender; and

- (c) provide an instruction not to open before the specified time and date for Tender opening.
- (d) If the envelope is not sealed and marked as instructed above, the Employer will assume no responsibility for the misplacement or premature opening of the tender.

4.2 Tenders shall be delivered to the Employer at the address specified not later than the time and date specified in the Invitation to Tender.

4.3 The Tenderer shall not submit alternative offers unless they are specifically required in the Tender documents.

Each Tenderer may submit only one Tender. Any Tenderer who fails to comply with this requirement will be disqualified.

4.4 Any Tender received after the deadline for submission will be returned to the Tenderer un-opened.

4.5 The Employer may extend the deadline for submission of Tenders by issuing an amendment in accordance with paragraph 2.5 in which case all rights and obligations of the Employer and the Tenderers previously subject to the original deadline will then be subject to the new deadline.

4.6 The Tender Security shall be valid **at least twenty Eight (28) days beyond the tender validity period**. Any tender not accompanied by an acceptable Tender Surety will be rejected by the Employer as non-responsive.

5. Tender Opening

5.2 The Tenders shall be opened in the presence of those Tenderers' representatives who choose to attend at the time and in the place specified in the Invitation to Tender.

5.2 The name of the Tenderer, the total amount of each Tender and the status of the Tender Security shall be read out and recorded in a Tender Opening register, a copy of which may on request be made available to any Tenderer. Minutes of the Tender opening, including the information disclosed to those present shall also be prepared by the Employer.

6. Tender Evaluation

6.1 Information relating to the examination, clarification, evaluation and comparison of Tenders and recommendations for the award of the Contract shall not be disclosed to Tenderers or any other persons not officially concerned with such process until the award to the successful Tenderer has been announced. Any effort by a Tenderer to influence the Employer's officials, processing of Tenders or award decisions will result in the rejection of the Tender.

6.2 Prior to the detailed evaluation of Tenders, the Employer shall determine if each Tender:-

- a) Meets the eligibility criteria defined in paragraphs 1.2 and 1.5.
- b) Has been properly signed;
- c) Is accompanied by the required Securities;
- d) Is substantially responsive to the requirements of the Tender documents.

6.3 The Employer will reject any Tenders deemed to be non-responsive on the above criteria.

6.4 A substantially responsive Tender is one which conforms to all the terms, Conditions and Specifications (to be annexed during contract signing) of the Tender documents, without material deviation or reservation. A material deviation or reservation is the one:-

- a) which affects in any substantial way the scope, quality or performance of the Works;
- b) which limits in any substantial way, inconsistent with the Tender documents, the Employer's rights or the Tenderer's obligations under the Contract;
- c) whose rectification would affect unfairly the competitive position of other Tenderers presenting substantially responsive Tenders.

- 6.5 Tenders determined to be substantially responsive and within the Engineers Estimate will be checked for any arithmetic errors. Errors will be corrected as follows:
- (a) where there is a discrepancy between the amount in figures and the amount in words, the amount in words shall prevail;
 - (b) where there is a discrepancy between the arithmetically correct line item Amount, resulting from the multiplication of the Unit Rate and the Quantity, and the Amount entered, the latter shall prevail and the Unit Rate shall be adjusted accordingly.
 - (c) for Lumpsum items, only the Amount will be considered, disregarding any filled in unit rate.
 - (d) where there is a discrepancy between the Tender Price as stated in the Form of Tender and the Tender total in the main Summary of the Bills of Quantities, the Tender Price shall prevail. The Employer shall notify the Tenderer and request that the Tenderer agrees to the Tender Price. The Unit Rate for the Items where the discrepancy occurs shall be adjusted by the Engineer. If the Tenderer fails to accept the corrected figure the Tender shall be rejected and the Tender Security shall be forfeit. Any discrepancy greater than 15% of the corrected figure shall result in rejection of the Tender and the forfeit of the Tender Security.

6.6 The Employer at his discretion may request any Tenderer for clarification of the Tender, including a breakdown of Unit Rates. The request for clarification and the response shall be in writing or electronic means.

7. Award of Contract

7.1 **Criteria of Award:** Subject to ITT Clause 35 and 36, the Procuring Entity will award the Contract to the Tenderer whose Tender has been determined to be substantially responsive to the Tendering documents and who has offered the lowest Evaluated Tender Price, provided that such Tenderer has been determined to be:

- a) Eligible in accordance with the provisions of ITT Clause 3;
- b) Is determined to be qualified to perform the Contract satisfactorily;
- c) Successful negotiations have been concluded.

7.2 **Clarifications:** Clarifications may be undertaken with the lowest evaluated Tenderer relating to the following areas:

- a) A minor alteration to the technical details of the statement of requirements;
- b) Reduction of quantities for budgetary reasons, where the reduction is in excess of any provided for in the Tendering documents;
- c) A minor amendment to the Contract Data Sheet;
- d) Finalizing payment arrangements;
- e) Mobilization arrangements;
- f) Agreeing final delivery or work schedule to accommodate any changes required by the Procuring Entity;
- g) The methodology or staffing; or
- h) Clarifying details that were not apparent or could not be finalized at the time of Tendering.

7.3 **Maximum value of award per bidder:** No bidder will be awarded more than two (2) contracts.

7.4 **Procuring Entity's Right to Accept any Tender and to Reject any or all Tenders:** The Employer reserves the right to accept or reject any or all Tenders and to cancel the Tendering process at any time prior to the award of the Contract without thereby incurring any liability to the affected Tenderer or Tenderers or any obligation to inform the affected Tenderer(s) of the grounds for the action.

7.5 **Procuring Entities Right to Vary Quantities at the Time of Award:** The Procuring Entity reserves the right at the time of

contract award to increase or decrease the quantity of goods or related services originally specified in these Tendering documents (BoQ), without any change in unit price or other terms and conditions of the Tender and Tendering documents.

- 7.6 Notification of Award:** The Tenderer whose Tender has been accepted will be notified of the award prior to the expiration of the Tender validity period in writing or by electronic means. This notification (called the "Letter of Acceptance") will state the sum (called the "Contract Price"] which the Employer will pay the Tenderer in consideration of the execution, completion, and maintenance of the Works as set out in the Contract. The Letter of Acceptance will constitute a binding Agreement, prior to the Tenderer signing the Contract Agreement.
- 7.7 Signing of Contract:** The Contract Agreement will incorporate all agreements between the Employer and the Tenderer. It will be signed by the Tenderer, not earlier than 14 days following the date of the Letter of Acceptance, and thereafter returned to the Employer within 7 days for signature.
- 7.8 Completion:** After completion of the work, the Contractor will serve a written notice to the Engineer in Charge to this effect. The Engineer in Charge upon receipt of this notice shall conduct a complete joint survey of the work within seven (7) days and enable the appointed Inspection and Acceptance Team to visit and make recommendations.

TECHNICAL EVALUATION CRITERIA

This Section shall apply to tenderers whose bids have been determined to be responsive and have met all the Qualification Criteria as per the instruction to bidders.

It contains all the factors, methods and criteria that the Procurement Entity shall use for the technical evaluation. The information to be provided in relation to each factor and the definitions of the corresponding terms are included in the respective supplementary information Forms (Schedules).

The Technical Evaluation Committee shall examine tender documents and score them based on their validity, accuracy and quality. Where the bidder fails to meet the requirement, the bidder shall be disqualified.

7.1 Qualification Checklist for Completeness and Responsiveness

S/No.	Completeness and responsiveness criteria	References	Required
1	Form of Bid	Schedules/Standard Form	Amount must be indicated, Properly fill and sign
2	Bid Security	Invitation Letter	At least thirty (30) days beyond the tender validity period in the form prescribed
3	Eligibility	ITT, Schedules & Standard Form	Copies of National ID or passport for all directors - Certified copy of Form CR12 - Proof of registration with the National Treasury or the respective County Treasury (for C,D,E - YW&D Group)
4	Confidential Business Questionnaire	ITT, Schedules & Standard Form	Properly fill and sign and Provide all information requested
5	Conflict of Interest	ITT, Schedules & Standard Form	State explicitly
6	Tax Compliance Certificate; Certificate of Incorporation; VAT & PIN registration	ITT clause 1.2	Certified copies by commissioner of Oaths, Valid as at the date of Tender opening
7	Registration with N.C.A.	ITT clause 1.2	Class 7 and above, Certified copies by commissioner of Oaths
8	Form of Power of Attorney	ITT, Schedules & Standard Form	Properly fill and sign
9	All Schedule s (Major Items of Plant; Key Personnel; Roads Works Completed; Ongoing works; Litigation status and History of Non-performance; and other supplementary and financial standing) in required formats and timelines	ITT, Schedules & Standard Form	Fill properly in the format given and sign
10	Work Execution Programme	ITT, Schedules & Standard Form	Must be provided in the format given, brief and to the point
11	Priced Bill of Quantities	ITT, Schedules & Standard Form	Fill all rates, prices and amounts
12	Preparation of the Tenders	ITT, Schedules & Standard Form	The Forms, BOQ and Schedules provided in the tender documents to be properly filled without exception
13	Serialization	ITT 3.2 (e)	Duly serialized tender document (Every page of the bid document must be serialized)
Terms			Must have met all above

7.2 Technical Evaluation Criteria

This Section shall apply to tenderer whose bids have been determined to be responsive and have met all the Qualification Criteria as per the instruction to bidders.

It contains all the factors, methods and criteria that shall be used for the technical evaluation. The information to be provided in relation to each factor and the definitions of the corresponding terms are included in the respective supplementary information Forms (Schedules). **Schedules not complying with the format attract half marks.**

TABLE 7.1 CONTRACTORS CAPABILITY TO SUPERVISE AND PERFORM THE WORKS				
Qualification Criteria		Submission Requirement	Compliance and Documentation	Score
Item	Subject			
Contractors Capability to supervise and perform the work	Equipment holding	Bidder to submit the following in accordance with: - Ownership list and proof of required equipment and/or Authorization letter of hiring from M&T or reputable hiring company	Schedules & Standard Form	20
	Key Personnel	Provide List of professional and technical staff and their resume in accordance General Experience (CV), Certified Qualification Certificate,	Schedules & Standard Form	15
	Past relevant work Experience	Bidder to submit the following in accordance with Completion certificate, Taking Over Certificate and/or Substantial Completion Certificate of relevant work in the previous 2 years	Schedules & Standard Form	15
	Contractual misconducts and litigation	Record of contractual misconduct in the previous 1 year ITT and Schedules Record of litigation in the previous 1 year. Attach affidavit	Schedules & Standard Form	5
	Financial Capability	Bidder to submit the following in accordance with ITT and Schedules <i>Certified audited accounts for the last Two [2] and projection of next 1 (One) years Banks statement (last 3 months)</i>	ITT 1.2, Schedules & Standard Form	15
Sub Total Score				70

For companies or firms that are registered or incorporated within the last one calendar year of the Date of the Tender Document, they should submit certified copies of bank statements covering a period of at least six months prior to the date of advertisement. The copies should be certified by the Bank issuing the statements. The certification should be original

All Agreements and Authorization letters must have been renewed within the last six (6) months from the date of advertisement.

Equipment Holding & Line of Credit, Cash flow statement will be exempted for YW&D Category *
WEP not complying with the format below attracts half marks.

TABLE 7.2: CONTRACTORS TECHNICAL PROPOSAL AND WORKS EXECUTION PROGRAMME

Qualification Criteria		Submission Requirement	Compliance Requirement	Score
Item No.	Subject			
1	Mobilization Management plan	Bidder to submit the following Proposals: Site layout plan and material mobilization Site Organization Chart Equipment management plan Personnel mobilization	Schedule 9	6
2	Quality and Quantity Management	Bidder to submit the following Proposals: Methodology Proposals on material testing Proposal on measurements Photograph plan	Schedule 9	10
3	Working Schedule and Projected Cash flow.	Bidder to submit the following Proposals: Signed work programme chart Signed Cash flow plan during the contract period.	Schedule 9	4
4	Work safety management	Bidder to submit the following Proposal; Proposals on traffic control workers safety & accident prevention	Schedule 9	5
5	Environmental and social management	Bidder to submit the following Proposals; Proposal on environmental and social mitigation measures	Schedule 9	5
Technical Proposal and comments Sub Total Score				30
GRANT TOTAL TECHNICAL SCORE				100

Bidders whose shall **score 85%** and above shall proceed to financial evaluation stage.

SECTION B:

PART I: GENERAL CONDITIONS OF CONTRACT	19
PART II: CONDITIONS OF PARTICULAR APPLICATION	20
1 GENERAL PROVISIONS	20
1.1 Definitions	20
1.2 Interpretation	20
4 THE CONTRACTOR	20
4.1. General Obligations	20
4.1.1. R2000 Strategy	20
4.1.2 Approval of Equipment	20
4.1.3 Recruitment of Labour	21
4.1.4. Employment of Young Persons and Children	21
4.1.5. Conditions of Employment of Labour	21
4.1.6. Reporting Requirements	21
4.1.7. Non-payment of Wages by Contractor	21
4.1.8. Contract with Employees	21
4.1.9. Water for the Works	22
4.1.10. Environment	22
4.1.11. HIV/AIDS	22
4.2. Performance Security	22
7. TIME FOR COMPLETION	23
7.1 Execution of the Works	23
7.1.1 Progress Review Meetings	23
7.2 Programme	23
7.2.1 Intended Construction Procedures, Order and Methods	23
7.2.2 Programme Updating	23
10. VARIATIONS AND CLAIMS	23
10.2 Permitted Variations	23
11. CONTRACT PRICE AND PAYMENT	23
11.1. Valuation of the Works	23
11.1.1. Price Adjustment	23
11.1.2. Exclusion of Price Adjustment for Late Completion of Works	24
11.1.3. Dayworks	24
11.2. Interim Payments	24
11.2.1. Advance Payment	25
11.2.2. Deductions for Re-payment of Advance Payment	25
11.2.3. The Minimum Amount of Interim Payment.	25

PART II: CONDITIONS OF PARTICULAR APPLICATION

The Conditions of Particular Application amplify the FIDIC Short Form of Contract so as to be, together, applicable to the Contract.

1 GENERAL PROVISIONS

1.1 Definitions

Add new Paragraph to sub-clause 1.1.8

1.1.8 (a) **“Week”** means a period of seven (7) consecutive days

1.1.8 (b) **“Month”** means calendar month

Add new paragraph to sub-clause 1.1.20 to 1.1.25

1.1.20 **“Appendix”** as referred to in the Conditions of Contract means Appendix to Form of Agreement.

1.1.21 **“Labour-Based Methods”** means work methods whereby activities are carried out using labour where technically and economically viable and appropriate equipment is only used when labour alone will not achieve the required standards.

1.1.22 **“Task”** means the amount of work to be done by one individual worker or a gang in order to earn one day’s wage.

1.1.23 **“Young Person”** means an individual male or female, who has attained the age of 16 years but has not attained the age of 18 years.

1.1.24 **“R2000 Strategy”** means an initiative by the Government of Kenya to improve the maintenance of the country’s Road Network by giving priority to maintenance through network approach, using appropriate technology, labour-based methods, local resources and increased usage of small-scale entrepreneurs.

1.2 Interpretation

Add sub-clause 1.2.1 as follows

1.2.1 Words having the same meaning

In the Contract Documents the Employer’s Representative is generally designated as the Engineer.

4 THE CONTRACTOR

4.1. General Obligations

Add. In particular the following obligations shall apply

Add the following new sub-Clauses:

4.1.1. R2000 Strategy

The Works shall generally be carried out using the R2000 Strategy and work approach, with its predominant emphasis on the use of labour-based construction methods where they are technically and economically viable. Intermediate equipment, as agreed by the Engineer may be used in other appropriate circumstances.

4.1.2 Approval of Equipment

The Contractor shall submit for the Engineer’s approval within seven days prior to the commencement date a list of equipment, which is intended for use on site. He shall notify the Engineer prior to bringing in equipment and shall further obtain the Engineer’s approval prior to removing any equipment from site.

4.1.3 Recruitment of Labour

4.1.3.1 The Contractor shall ensure that there is a sufficient and suitable deployment of labour at all times throughout the Contract.

4.1.3.2 All general workers employed by the Contractor shall, to the extent possible, be recruited from the surrounding population. Exceptions may be made if sufficient local labour cannot be recruited and only with the approval of the Engineer. There shall be no discrimination in recruitment based on tribe, religion, political affiliation, age, disability or gender, and the recruitment system shall be fair and transparent.

4.1.3.3 4.1.3.3 The Contractor shall take particular note of the Government policy regarding the employment of women and youth in the recruitment process and shall take all possible steps to attain the targets of 30% of the labour force for each group.

4.1.4. Employment of Young Persons and Children

The Contractor shall comply with the Employment Act Chapter CAP 226 concerning the Employment of Young Persons and Children.

4.1.5. Conditions of Employment of Labour

The Contractor shall observe and fulfil the following conditions in respect of all persons employed by him in the execution of the Contract: -

- a) Where possible, labour shall be employed on a daily task basis. The size of the daily task shall be that which can reasonably be expected of a worker during a normal working day (8 hours), and all task rates shall be approved by the Engineer.
- b) The Contractor shall pay wage rates and observe hours and conditions of employment of labour as established by Kenyan Labour Laws and by agreement between Employers or other recognized authorities and trades unions for similar trades or industries in the District where the Contract Works are to be carried out.
- c) The Contractor shall recognize the freedom of employees to be members of trades unions. The Contractor's attention is drawn to the requirements of the Trade Unions Act (CAP 233), which states that if at least 25% of the employees are members of a particular Trade Union Organisation, then the Contractor is legally bound to recognise and negotiate with the Organisation.

4.1.6. Reporting Requirements

The Contractor shall, when required by the Engineer, submit labour returns in such form and detail and at prescribed intervals showing the staff and the number of the several classes of labour employed by the Contractor.

4.1.7. Non-payment of Wages by Contractor

- (a) The Employer may demand from the Contractor reasonable proof of payment of wages to the employees.
- (b) The Employer may, upon the Contractor defaulting in payment, pay the money due, out of any funds due or which may become due to the Contractor under the Contract.
- (c) In such an event, the Contractor shall co-operate with the Employer in processing the payment of the correct amounts of money due to the labour force by submitting the relevant muster rolls, workday reports and pay-sheets, and the Contractor shall be represented at the time payments are made.
- (d) Direct payment to workers by the Employer shall attract a penalty as stated in the Appendix to cover expenses incurred in the administration of such labour payments.

4.1.8. Contract with Employees

- (i) Working days
The Contractor shall recognize gazetted non-working days and allow in the Works Programme for those days on

which labour is not expected to work.

(ii) Provision of Hand Tools

The Contractor shall provide his labour force with a sufficient number of hand tools of good quality and shall make the necessary provisions to maintain the tools in a good and safe working condition. The Engineer may instruct the Contractor to replace worn out, faulty or unsafe hand tools.

(iii) Safety and Health

(a) The Contractor shall be responsible for the safety of all workers. In collaboration with, and to the requirements of the local health authorities, the Contractor shall ensure that first aid equipment and medical stores are available on the Site at all times throughout the period of the Contract, and shall also designate a Health and Safety Officer from amongst the staff.

(b) The Contractor shall be responsible for the provision of potable water for the workers at appropriate locations on the Site.

(c) In the event of any outbreak of illness of an epidemic nature the Contractor shall comply with and carry out such regulations, orders and requirements as may be made by the Government or the local medical or sanitary authorities for the purpose of dealing with and overcoming the same.

(iv) Contractor to Preserve Peace

The Contractor shall take all reasonable measures to ensure that all personnel on site comply with the Statutes, Ordinances, Laws, Regulations and By-Laws in force in Kenya, and to prevent accidents or any riotous or unlawful behaviour by or amongst the employees on or in connection with the Works, and for the preservation of the peace.

4.1.9. Water for the Works

The Contractor shall supply all water for the Works.

4.1.10. Environment

The Contractor shall take all reasonable measures to protect the environment on the Site and to avoid damage or nuisance to persons and property. In particular, the Contractor shall carry out all activities in a manner that ensures:-

- a) Minimum soil erosion on slopes and sedimentation deposition in the drainage works;
- b) Maximum preservation of trees and shrubbery;
- c) No entrance or accidental spillage of solid matters, debris and other pollutants and waste into water courses
- d) The safe disposal of rubbish and waste.

4.1.11. HIV/AIDS

The Contractor shall institute on-site HIV/AIDS awareness and prevention campaigns for the duration of the Contract. This shall include the siting of information posters, the issue of condoms and also informatory meetings on site for the employees. The meetings shall be arranged with the assistance of the local health authorities and AIDS Campaign personnel, and shall be during working hours without loss of pay.

4.2. Performance Security

Add the following at the end of this clause.

The Performance Security shall be valid until the date of issue of the Employer's notice under sub-Clause 8.2 (Taking Over Notice). The Employer shall return the Security to the Contractor within 14 days thereafter.

A Performance Security in the form an Insurance Bond shall only be allowed from an Insurance Company approved by the Public Procurement Oversight Authority (PPOA) and in a Form also approved by the PPOA.

7. TIME FOR COMPLETION

7.1 Execution of the Works

Add new sub-clause to 7.1.1:

7.1.1 Progress Review Meetings

Regular progress review meetings between the Employer and the Contractor shall be held at times decided by the Engineer.

7.2 Programme

Add two new paragraphs under this Sub-Clause

7.2.1 Intended Construction Procedures, Order and Methods

The Contractor shall show in the Programme of Works, the procedure, order and methods proposed for carrying out Works with specific emphasis on the labour requirements, equipment utilisation and productivity.

7.2.2 Programme Updating

Within the intervals stated in the Appendix or as required by the Engineer the Contractor shall submit an updated Programme of Works.

10. VARIATIONS AND CLAIMS

Add the following sub-clauses:

10.2 Permitted Variations

(d) The Engineer shall not be permitted to issue Variations to a value greater than the Tender Sum without approval from the Procurement Entity. The limit of approved Variations shall be + 15% of the Tender Sum.

11. CONTRACT PRICE AND PAYMENT

11.1. Valuation of the Works

Add the following sub-clauses:

11.1.1. Price Adjustment

The Contract shall not normally be subject to Price Adjustment. However, in exceptional and clearly identifiable economic circumstances, the Employer may consider a request from the Contractor for Price Adjustment where taxes, duties and/or basic costs for labour and specified materials have significantly increased since the commencement of the Works, as set out below,

(a) Local Labour

For the purpose of this Sub Clause:

(i) "Local Labour" means skilled, semi-skilled workers of all trades engaged by the Contractor on the Site for the purpose of or in connection with the Contract or engaged full time by the Contractor off the site for the Purpose of or in connection with the Contract (by way of illustration but not limitation: workers engaged full time in any office, store, workshop or quarry).

(ii) "Basic Rate" means the applicable basic minimum wage rate prevailing on the date 28 days prior to the latest date for submission of Tenders, by reason of any National or State Statute or Ordinance.

(iii) "Current Rate" means the applicable basic minimum wage rate for Local Workers by reason of any National or State Statute or Ordinance, prevailing on any date subsequent to the date 28 days prior to the latest date set for submission of Tenders.

b) Specified Materials

For the purpose of this Sub-Clause

(i) "Specified Materials" means the basic materials required on the Site for the execution and completion of Works, which shall include fuel and lubricants; cement; aggregates; steel reinforcement; timber and gravel.

(ii) "Basic Prices" means the prices for the specified materials prevailing on the date 28 days prior to the latest date for submission of Tenders.

The Engineer shall compile a Schedule of Basic Prices, upon which any claim for Variation shall be based, prior to the award of the Contract. The Contractor shall be entitled to a copy of the Schedule upon request to the Engineer.

(iii) "Current Prices" means the prices for the specified materials prevailing on any date subsequent to the date 28 days prior to the latest date set for the submission of the Tenders, by reason of any National or State Statute or Ordinance,

(c) Overheads and Profits Excluded

In determining the amount of any adjustment to the Contract Price pursuant to this Sub-Clause no account shall be taken of any overheads or profits.

(d) Adjustments

The net amount of difference between the basic price and the current price payable by the Contractor when the specified services are provided or materials are bought shall, as the case may be, be paid to the Contractor.

(e) Notice and Records

The Contractor shall keep such books, accounts, invoices, receipts, time sheets and other documents and records as are necessary to enable any adjustment under this Clause to be made and shall at the request of the Employer furnish these duly verified in such a manner as the Employer may require for examination and checking.

11.1.2. Exclusion of Price Adjustment for Late Completion of Works

In the event of the Contractor failing to complete the Works within the Time of Completion as defined under Clause 7, or extension of the Contract period granted, the provisions of Clause 11 shall cease to apply.

Any part of the Works executed after the expiry of the Time for Completion shall be valued at a price levels prevailing at the contractual date of Completion.

11.1.3. Dayworks

The Contractor shall not execute any work on a Dayworks basis except by written order of the Engineer

Unless otherwise adjusted, payments for Dayworks shall be subject to price adjustment in accordance with the provisions of Clause 11.1.1

11.2. Interim Payments

Add the following sub-clauses:

11.2.1. Advance Payment

The Employer may make Advance Payment to the Contractor on application after signing the Contract, against a Bank Guarantee, or approved Insurance Bond, in the form set out in the Tender Documents

This Advance Payment shall be up to a maximum amount stated in the Appendix.

11.2.2. Deductions for Re-payment of Advance Payment

Reimbursements of Advance Payment shall be made according to the schedule as stated in the Appendix.

11.2.3. The Minimum Amount of Interim Payment.

The minimum amount of an Interim Payment shall be stated in the Appendix.

STANDARD FORMS

CONTENTS:

- (i) Letter of Acceptance**
- (ii) Tender Questionnaire**
- (iii) Form Of Written Power Of Attorney**
- (iv) Confidential Business Questionnaire**

LETTER OF ACCEPTANCE

[letterhead paper of the Employer]

_____ *[date]*

To: _____
[name of the Contractor]

[address of the Contractor]

Dear Sir,

This is to notify you that your Tender dated _____ for the execution of

[name of the Contract and identification number, as given in the Tender documents] for the Contract Price of

Kshs. _____ *[Amount in figures]* Kenya Shillings _____

_____ *[Amount in words]* in accordance with the Instructions to Tenderers is hereby accepted.

You are hereby instructed to proceed with the execution of the said Works in accordance with the Contract documents.

Authorized Signature

Name and Title of Signatory

Attachment

:

TENDER QUESTIONNAIRE

Please fill in block letters.

1. Full name of Tenderer;

2. Full address of Tenderer to which Tender correspondence is to be sent (unless an agent has been appointed below);

3. Telephone number (s) of Tenderer;

4. Facsimile of Tenderer;

5. Name of Tenderer's representative to be contacted on matters of the Tender during the Tender period;

6. Details of Tenderer's nominated agent (if any) to receive Tender notices (name, address, telephone, telefax);

(Signature of Contractor)

(Date)

FORM OF WRITTEN POWER OF ATTORNEY

(Name of Bidder's

The Bidder shall state here below the name(s) and address of his representative(s) who is/are authorized to receive on his behalf correspondence in connection with the Tender.

Representative in block letters)

(Address of Bidder's Representative)

(Name of Bidder's

(Signature of Bidder's Representative)

Alternate:

Representative in block letters)

(Address of Bidder's Representative)

(Signature of Bidder's Representative)

***To be filled by all Bidders.**

CONFIDENTIAL BUSINESS QUESTIONNAIRE

This Confidential Business Questionnaire of the Government of Kenya shall be completed by the Bidder or by each member of a Joint venture if the Bidder is a Joint-venture.

REPUBLIC OF KENYA

CONFIDENTIAL BUSINESS QUESTIONNAIRE

You are requested to give the particulars indicated in Part 1 and either Part 2 (a), 2(b) or 2(c) whichever applies to your type of business. You are also advised that it is a serious offence to give false information on this Form.

Part 1 - General:

Business Name:.....

Location of Business Premises

Plot No...... *Street/Road*.....

Postal Address..... *Tel No*

Nature of Business.....

Current Trade License No*Expiring Date*

Maximum value of Business which you can handle at any one time: Kshs

Name of your Bankers.....

Branch

Part 2(a) - Sole Proprietor:

Your Name in full

Age: *Nationality*.....*Country of Origin*.....

**Citizenship details*.....

****Attach CR12 and Copy of Citizenship (Compulsory).***

Part 2 (b) - Partnership

Give details of partners as follows:

	Name in full	Nationality	Citizenship Details	Shares
1				
2				
3				
4				
5				

Note: Attach CR12 and proof of citizenship (Compulsory)

Part 2 (c) - Registered Company

Give details of directors as follows:

Private or public

State the nominal and issued capital of the company-

Nominal Kshs.....

Issued Kshs.

	Name in full	Nationality	Citizenship Details	Shares
1				
2				
3				
4				
5				
6				

Note: Attach CR12 and proof of citizenship (Compulsory)

Part 2 (d) Interest in the Firm:

alongside as necessary.

Yes	No

(Signature of Contractor)

(Date)

SCHEDULES OF SUPPLEMENTARY INFORMATION

SCHEDULE 1: MAJOR ITEMS OF CONSTRUCTION PLANT AND EQUIPMENT (.....)	33
SCHEDULE 2: KEY PERSONNEL	34
SCHEDULE 3: SCHEDULE OF ROADWORK'S CARRIED OUT IN THE LAST TWO YEARS	35
SCHEDULE 4: SCHEDULE OF ONGOING PROJECTS	36
SCHEDULE 5: SCHEDULE OF LOCAL LABOUR BASIC RATES	37
SCHEDULE 6: SCHEDULE OF FINANCIAL ASSESSMENT	38
SUMMARY OF ASSETS AND LIABILITIES OF THE AUDITED FINANCIAL STATEMENTS OF THE LAST TWO (2) FINANCIAL YEARS	38
SCHEDULE 7: OTHER SUPPLEMENTARY INFORMATION	39
SCHEDULE 8: DECLARATION OF TENDERER'S KNOWLEDGE OF SITE	40
SCHEDULE 9: WORK EXECUTION PROGRAMME	41
SCHEDULE 10: ANTI-CORRUPTION DECLARATION COMMITMENT/ PLEDGE	44

SCHEDULE 1: MAJOR ITEMS OF CONSTRUCTION PLANT AND EQUIPMENT

The Tenderer shall provide adequate information to demonstrate clearly that it has the capability to meet the requirements for the key equipment listed in **Schedule of the Major Items of Plant to Be Used On the Proposed Contract**. A separate Form shall be prepared for each item of equipment listed, or for alternative equipment proposed by the Tenderer. The Tenderer shall provide all the information requested below, to the extent possible.

The Bidder must indicate the main plant and equipment considered by the company to be necessary for undertaking the project together with proof ownership.

Item No.	Equipment Details	Minimum Number Required	No of owned/Leased by the Bidder	No of to be availed for the project
1	Motor Graders	1		
2	Dozer D6 or equivalent	0		
3	Front end loaders	0		
4	Tipper, 7 Tonnes	3		
5	Rollers	1		
6	Water tankers 5,000 litres	0		
7	Excavator	1 (optional)		
8	Concrete Mixers	1		
9	Poker vibrator	1		
10	Pedestrian Roller	1 (Optional)		

I/We certify that the above information is correct and include attachments as per Schedule 1.
(Date)

(Signature of Contractor)

SCHEDULE 2: KEY PERSONNEL

The Bidder shall list in this schedule the key professional and technical personnel he will employ, providing Proof of qualifications, experience, position held and nationality.

SUMMARY OF QUALIFICATIONS

DESIGNATION	NAME	NATIONALITY	Education	AND EXPERIENCE	
				General	Relevant
Experience	Experience (Yrs)	(Yrs)			

Headquarters

Partner/Director or other key staff (give designation)

Site Office

Site Agent

Deputy Site Agent/Site Engineer.

Senior Foreman

Construction supervisors Site Surveyor

Other Key Staff

Foremen

(i) Earthworks

(ii) Concrete

(iii) Concrete

(iv) Pavement

(v) Drainage

Note: The Bidder shall list in this schedule the key personnel he will employ from the Contractor’s headquarters and from the Contractor’s site office to direct and execute the work together with their qualifications, experience, position held and nationality in accordance (where required, use separate sheets to add extra data for column 4).

Bidders shall attach academic certificates of qualifications, CV’s of key personnel which should be signed by the staff on or after the date of invitation of bid and certified by a Commissioner of Oaths.

I certify that the above information is correct.

(Signature of Contractor)

(Date)

Note: Please attach Certified Copies of Highest Qualification Certificates ONLY

DESCRIPTION OF WORKS	CLIENT'S NAME	VALUE OF WORKS (KShs) *	YEAR COMPLETED REMARKS

I certify that the above works were successfully carried out (**Attach Completion Certificates / Substantial completion certificate.**

I certify that the above works were successfully carried out by this Contractor.
 (Signature of Contractor) (Date)

Name of Signatory:

SCHEDULE 5: SCHEDULE OF LOCAL LABOUR BASIC RATES

DESCRIPTION	DATE OF COMMENCEMENT	DATE OF COMPLETION	VALUE OF WORKS (KSHS)	VALUE COMPLETE D UP TO DATE %	PHYSICALLY COMPLETED UP TO DATE %

I certify that the above works are being carried out by me and that the above information is correct.

(Signature of Contractor)

(Date)

SCHEDULE 5: SCHEDULE OF LOCAL LABOUR BASIC RATES

The rates inserted in this schedule will be those used in determining changes in cost of local labour as provided in Clause 4.1.3 of the Conditions of Contract Part 2.

Variation of price on Labour not payable.

LABOUR CATEGORY	MONTH/SHIFT/HOUR	UNIT	RATE (KShs)
Skilled Labour Semi-Skilled Labour			

NOTE: Categories to be generally in accordance with those used by the Kenya Building Construction Engineering and Allied Trade Workers Union and Ministry of labour

I certify that the above information is correct.

(Signature of Contractor)

(Date)

Name of Signatory:

SCHEDULE 6: SCHEDULE OF FINANCIAL ASSESSMENT

1. Submit copies of audited profit and loss statements and balance sheet for the last two calendar years and estimated projection for the next one (1) year with certified English translation where appropriate.
2. Give turnover figures for each of the last two (2) financial years. Quote in millions and decimal thereof.

Type of Work	Year 20	Year 20.....	Projection Year 20
	Kshs.	Kshs.	Kshs.
Road works			
Other civil engineering works			
Other (specify)			
Total			

SUMMARY OF ASSETS AND LIABILITIES OF THE AUDITED FINANCIAL STATEMENTS OF THE LAST TWO (2) FINANCIAL YEARS

	Year 20	Year 20	Projection Year 20
	Kshs.	Kshs.	Kshs.
1. Total Assets			
2. Current Assets			
3. Bank credit Line Value			
4. Total Liabilities			
5. Current Liabilities			
6. Net worth (1-4)			
7. Working capital (2+3-4)			

(a) Name/Address of Commercial Bank providing credit line

Total amount of credit line Kshs

(Attach a certified copy of the current Letter of Line of credit from the Bank.)

(b) **Attach certified copies of financial bank statements of the last three (3) months.**

Name, address, telephone, telex, fax numbers of the Tenders' Bankers who may provide reference if contacted by the Contracting Authority.

I certify that the above information is correct.

(Signature of Contractor)

(Date)

Name of Signatory:

SCHEDULE 7: OTHER SUPPLEMENTARY INFORMATION

1. Financial reports for the last two years and projection of next 1 year, balance sheets, profit and loss statements, auditors' reports etc. List them below and attach copies.

2. Evidence of access to financial resources to meet the qualification requirements. Cash in hand, lines of credit etc. List below and attach copies of supporting documents. Lines of Credit should be supported by credit ratings from a recognised Credit Rating Bureau approved by the Central Bank of Kenya (Otherwise they will be assumed to be invalid).

3. Name, address, telephone, telex, fax numbers of the Bidders Bankers who may provide reference if contacted by the Contracting Authority.

4. Information on current litigation in which the Bidder is involved.

OTHER PARTY (IES)	CAUSE OF DISPUTE	AMOUNT INVOLVED (KShs)

Note: (Provide a sworn affidavit for both (a) and (b)).

I certify that the above information is correct

(Signature of Contractor)

(Date)

SCHEDULE 7: OTHER SUPPLEMENTARY INFORMATION

This is to certify that *[Name/s of representative]*

Being the authorized representative/Agent of *[Name of Contractor]*

M/s

has undertaken the inspection of site in accordance with the instruction to Bidders, for purposes of bidding for routine maintenance of

1. Having studied the tender document, I carefully examined the site to make myself familiar with the local conditions likely to influence the works and cost thereof.
2. I further certify that I am satisfied with the description of the works and I understand perfectly the scope of the works as specified and implied in the performance of the contract.
3. That I or our representatives have visited the site visit.
4. Signed **and Stamped**
(Bidder's Representative)

NOTE: This form Must be completed and duly signed.

SCHEDULE 9: WORK EXECUTION PROGRAMME

Give a brief description of how you plan to carry out the works within the contract period. The Works execution programme should include all relevant information to the project. The information given should be clear, not flawed description and compliance to standard and special specification in Tenderers Letterhead.

Note: Works Execution programme is different from form "programme of works referred in FIDIC and Standard Specification for Roads and Bridge Construction. The said "programme of works" is but part of Works Execution Programme (WEP).

The Contents of Works Execution Programme shall include:

- i. General information
 - a) Project data &
 - b) Scopes of works: A brief description of the project which includes major work items
- ii. Mobilization Management Plan
 - The Plan should show, the location of site office and site organization chart, Personnel management plan & Equipment management plan
- iii. Work execution schedule:

Signed Programme of works: It is desirable that work execution schedule includes time frame of each activity such as in bar chart format.
- iv. Quality and Quantity Management
 - Method statement: This includes Work procedures, order and methods for execution.
 - Proposal on material testing: Material and structural test methods and test laboratory
 - Proposal on measurements
 - Photograph plan: The bidder shall provide a photograph plan to record the progress and proof of quality control, measurement and any event that may arise.
- v. Safety management plan
 - This includes but not limited compliance with safety rules and regulation, traffic control and detour plans, emergency contact list.
- vi. Environmental plan
 - When the negative impacts on third parties during the execution are predicted, the management and mitigation plans should be included in WEP. Soil erosion on slopes and sedimentation deposition on the drainage works; Preservation of trees and shrubbery

Note:

Works Execution Programme to be submitted by the bidder shall not be less than five (5) pages covering all the above stated items.

Adjudicator’s Agreement

Identification of Project: (the “Project”)

Name and address of the Employer: (the “Employer”)

Name and address of the Contractor: (the “Contractor”)

Name and address of the Adjudicator: (the “Adjudicator”)

Whereas the Employer and the Contractor have entered into a Contract (“the Contract”) for the execution of the Project and wish to appoint the Adjudicator to act as adjudicator in accordance with the Rules for Adjudication [“the Rules”].

The Employer, Contractor and Adjudicator agree as follows:

- 1. The Rules and dispute provisions of the Contract shall form part of this Agreement.
- 2. The Adjudicator shall be paid:

A retainer fee ofper calendar month
(where applicable)

A daily fee of.....

Expenses (including the cost of telephone calls, courier charges, faxes and telexes incurred in connection with his duties; all reasonable and necessary travel expenses, hotel accommodation and subsistence and other direct travel expenses).

Receipts will be required for all expenses.

- 3. The Adjudicator agrees to act as Adjudicator in accordance with the Rules and has disclosed to the Parties any previous or existing relationship with the Parties or others concerned with the Project.
- 4. This Agreement shall be governed by the laws of Kenya
- 5. The Language of this Agreement shall be English

SIGNED BY

For and on behalf of the Employer in the presence of

Witness

Name

Address

Date

SIGNED BY

For and on behalf of the Contractor in the presence of

Witness

Name

Address

Date

SIGNED BY

For and on behalf of the Adjudicator in the presence of

Witness
Name
Address
Date

SECTION VIII: BILL OF QUANTITIES

UPGRADING TO BITUMEN STANDARDS KAPROGONYA ROAD

CONTRACT NO.

BILL NO. 1. PRELIMINARIES AND GENERAL ITEMS

ITEM	DESCRIPTION	UNIT	QTY	RATE	AMOUNT
1.04	Provide or rent and maintain Engineer's Site Laboratory for the duration of the Contract, ownership to revert to the Contractor at the end of the Contract	LS	1		
1.05	Provide and maintain Laboratory equipment, reagents and other items as priced in Appendix 'A' to the Bill of Quantities for use by the Engineer's representative for the duration of the Contract ownership to revert to the Employer at the end of the Contract.	LS	1		
1.06	Allow a Prime Cost Sum of Kshs.120,000.00 for the RE's miscellaneous account to be spent in whole or part as directed by the RE against receipts.	PC Sum	1	120,000	
1.07	Provide, erect and maintain publicity signboard as directed by the Engineer	No.	1	40,000	
1.08	Provide a prime cost for relocation of existing services	PC SUM		100,000	
1.09	Allow for the project registration with the relevant authorities.	ITEM	1	50,000	
1.10	Provide a prime cost for material testing	ITEM		100,000	
1.11	E.O. item 1.06-1.10 for Contractor's overheads and profits.	%			
Bill No. 1 Total Carried Forward to Grand Summary					

BILL NO. 4 : SITE CLEARANCE AND TOP SOIL STRIPPING

ITEM	DESCRIPTION	UNIT	QTY	RATE	AMOUNT
-------------	--------------------	-------------	------------	-------------	---------------

	<i>Note: No separate payments shall be made for gravel for blinding or hauling to spoil unsuitable excavation materials and the cost of such shall be included in the rates and prices</i>				
4.01	Clear site on road reserve including removal of all growths, bushes, hedges, trees, stumps, grub up roots, and other deleterious materials and back-fill and compact to 100% MDD(AASHTO T99) with approved material as directed by the Engineer.	Ha.	0.29		
4.02	Strip top soil up to 0.2m in thickness along alignment or material sites including removal of all grass and other vegetation, transport to spoil and spread or stock pile for re-use as directed by the Engineer.	M ²	2900		
4.03	Provide Kshs. 100,000 for the removal of structures and obstructions to be paid on day works basis	LS	1	100,000	
Bill No. 4 Total Carried Forward to Grand Summary					

BILL NO. 5 : EARTHWORKS

ITEM	DESCRIPTION	UNIT	QTY	RATE	AMOUNT
	<i>Note: No separate payments shall be made for gravel for blinding or hauling to spoil unsuitable excavation materials and the cost of such shall be included in the rates and prices</i>				
5.01	Excavate and spread in soft material and compact to 95% MDD (AASHTO T99) in layers not exceeding 150mm	m ³	870.00		

5.02	Ditto item 5.01 but in hard material	m ³	870		
5.03	Cut to spoil in soft material	m ³	400		
5,04	Ditto item 5.03 but in hard material	m ³	60		
5,05	Provide improved sub grade material to a thickness as shall be instructed by the Engineer and process, water and compact to 100% MDD (AASHTO T99)	m ³	0		
5.06	Process and compaction of 150mm original ground below fills and cuts to 95% MDD.(AASHTO T99)	M ²	5,000.00		
Bill No. 5 Total Carried Forward to Grand Summary					

BILL NO. 7 : EXCAVATION AND FILLING OF STRUCTURES

ITEM	DESCRIPTION	UNIT	QTY	RATE	AMOUNT
	<i>Note: No separate payments shall be made for gravel for blinding or hauling to spoil unsuitable excavation materials and the cost of such shall be included in the rates and prices</i>				
7.01	Excavate to spoil in soft materials.	m ³	10		
7.02	As item 7.01 but in hard material.	m ³	0		
7.03	Provide, place and compact Rockfill below and around structures.	m ³	13.6		
7.04	Provide and place 150mm thick stone pitching as directed by the Engineer including cement grouting	m ²	290		
7.05	Excavate for gabions in soft material.	m ³	10		
7.06	Provide and place gabion boxes and mattresses where directed by the Engineer.	No.	10		
7.07	Rockfill to gabions.	m ³	0		
7.08	Filter fabric behind gabion boxes.	m ²	0		
7.09	Provide concrete scour checks as	m ³	20		

	directed by the engineer				
	Bill No. 7 Total Carried Forward to Grand Summary				
BILL NO. 8. CULVERTS AND DRAINAGE WORKS					
ITEM	DESCRIPTION	UNIT	QTY	RATE	AMOUNT
	<i>Note: No separate payments shall be made for gravel for blinding or hauling to spoil unsuitable excavation materials and the cost of such shall be included in the rates and prices</i>				
8.01	Excavate for inlet, outfall, mitre and catch water drains in soft material	m ³	145		
8.02	As per item 8.01, but for hard material	m ³	145		
8.03	Excavation in soft material for pipe culverts, headwalls, wing walls, apron, toe walls and drop inlets and compact as directed by the Engineer	m ³	82		
8.04	As per item 8.03, but for hard material	m ³	82		
8.05	Provide, lay and joint 600mm dia. concrete pipes cast in situ for access roads	M	48		
8.06	As for item 8.05 but 900mm dia concrete pipes cast in situ for cross culverts	M	20		
8.07	Provide and place class 15/20 concrete to beds, surround and haunches	m ³	40		
8.08	Provide, place and compact class 25(20) concrete for headwalls, wing walls, aprons, and toe walls to access and cross pipe culverts including all form work and the provision and placing of reinforcement as shown in the drawings	m ³	12		
8.09	Provide and place BRC A 142 fabric mesh for head walls and wing walls as directed by the engineer	M ²	81.6		

Bill No. 8 Total Carried Forward to Grand Summary

BILL NO. 9: PASSAGE OF TRAFFIC

ITEM	DESCRIPTION	UNIT	QTY	RATE	AMOUNT
	NOTE: Notwithstanding the provision of Section 9 of the Standard Specification, no extra payments shall be due as all costs shall be deemed to be included in the rates inserted herein				
9.01	Allow for the passage of traffic through and around the works	LS	1	100,000	

Bill No. 9 Total Carried Forward to Grand Summary

BILL NO. 12 : NATURAL MATERIAL FOR SUBBASE AND BASE

ITEM	DESCRIPTION	UNIT	QTY	RATE	AMOUNT
	<u>Note: No overhaul will be paid for separately under these items as it shall be deemed to have been included in the Contractor's rates</u>				
12.01	Provide gravel sub-base material, haul, spread, compact to at least 100% M.D.D (AASHTO T-180) and shape to level and tolerance.	m ³	435		
12.02	Ditto item 12.01 but for base	m ³	305		

Bill No. 12 Total Carried Forward to Grand Summary

BILL NO. 14 : CEMENT OR LIME TREATED SUBBASE AND BASE

ITEM	DESCRIPTION	UNIT	QTY	RATE	AMOUNT
	<u>Note: No overhaul will be paid for separately under these items as it shall be deemed to have been</u>				

	<u>included in the Contractor's rates</u>				
14.01	Provide and spread Cement (42.5 Kn/m2) as an improvement agent for base	Tonnes	13.15		
14.02	Mix and process natural material with improvement agent for pavement layers as instructed by the Engineer or as specified	m ³	305		
14.03	Curing of cement / lime treated base and sub-base layers	m ²	2030		
Bill No. 14 Total Carried Forward to Grand Summary					

BILL NO. 15: BITUMINOUS SURFACE TREATMENT & SURFACE DRESSING TO SHOULDERS

ITEM	DESCRIPTION	UNIT	QTY	RATE	AMOUNT
15.01	Prepare surface of road base and shoulders, provide, heat and spray MC 30 cutback bitumen prime coat at 0.8-1.2 Litres/m2.	Litres	2436		
15.02	Provide & spray K-160 as tack coat on carriageway, rate of 0.5-0.8 l/m2	Litres	4872		
Bill No. 15 Total Carried Forward to Grand Summary					

BILL NO. 16: BITUMINOUS MIXES

ITEM	DESCRIPTION	UNIT	QTY	RATE	AMOUNT
16.01	Provide, lay and compact Asphaltic concrete Type I (0/14) binder course 35mm thickness binder course and wearing course on carriageway as directed.	M ³	71.05		
16.02	Provide, lay and compact Asphaltic concrete Type I regulating layer of	M ³	50.75		

	25mm thickness on the carriageway.				
	Bill No. 16 Total Carried Forward to Grand Summary				

BILL NO. 20: ROAD FURNITURE

ITEM	DESCRIPTION	UNIT	QTY	RATE	AMOUNT
20.01	Excavate for, provide & place 250 x 125mm precast concrete raised or ramped kerbs hunched in 100mm thick class 15/20 concrete base bedding and mortar joined in support to carriageway, busbays and junctions as directed by the Engineer.	M	580		
	a) Straight kerbs	M	0		
20.02	As 20.02 but for flush kerbs 100 x 125mm	M	0		
20.03	Provide, deliver, paint and mark the road as specified or as directed by the Engineer, with white reflect ionized thermoplastic paint from an approved supplier.	m ²	60.9		
20.04	As item 20.05 but for yellow reflect ionized thermoplastic paint	m ²	30.45		
	Bill No. 20 Total Carried Forward to Grand Summary				

BILL NO. 22: SCHEDULE OF DAYWORKS

ITEM	DESCRIPTION	UNIT	QTY	RATE	AMOUNT
	<u>PLANT</u>				
	<i>The rates inserted herein are to include all operational and Maintenance costs, fuel, oil, grease, drivers/operators wages, supervision, overheads and profit. Only time actually employed upon the work will be paid for and the rates should include for idle time, travelling time and overtime, In accordance with clause 2202 (a) of the specifications. Note: All items of plant must be priced.</i>				
22.01	Crawler dozers with hydraulic attachmentsto include ripper				
	a) Up to 135 kw rated flywheel power	Hrs	0		
	b) Over 136 kw rated flywheel power	Hrs	0		
22.02	Motor Grader				
	a) Up to 110kw rated flywheel power	Hrs	0		
	b) Over 100kw rated flywheel power	Hrs	0		
22.03	Vibratory Roller				
	a) 6.5 - 8.81 tonne un-ballasted weight	Hr	0		
	b) Over 8.91 tonne un-ballasted weight	Hr	0		
22.04	Hand propelled vibrating roller 650 - 1300kg	Hrs	0		
22.05	Cat 950G wheel loader or equivalent	Hrs	0		
22.06	10 Tonne tipper lorry	Hrs	0		
22.07	Small dumpers, 750-1000kg rated payload	Hrs	0		
22.08	Dual purpose hydraulic excavator with backhoe/loader and a rated bucket capacity of upto 1m3.	Hrs	0		

22.09	Articulated wheel loader with 1.5-2.0m3 SAE rated bucket capacity	Hrs	0		
22.1	50mm delivery water pump and motor	Hrs	0		
22.11	Self propelled water tanker 4,500ls min. capacity with pick-up pump	Hrs	0		
22.12	Concrete Mixer of 100 - 150litres	Hrs	0		
22.13	Concrete poker vibrator	Hrs	0		
	<u>LABOUR</u>				
	<i>The rates inserted herein are to include all costs of labour such as insurance, accomodation, travelling time, over-time, use and maintenance of small tools of trade. Only the actual time engaged upon the work will be paid for supervision, overheads and Profit.</i>				
22.14	Unskilled Labour	Hrs	0		
22.15	Artisans	Hrs	0		
22.16	Office attendants and chainmen	Hrs	0		
22.17	Watchmen (all round surveillance)	Hrs	0		
	TOTAL CARRIED FORWARD TO THE NEXT PAGE				
ITEM	DESCRIPTION	UNIT	QTY	RATE	AMOUNT
	TOTAL BROUGHT FORWARD				
	<u>MATERIALS</u>				
	<i>All materials are to comply with the Specification. The rates inserted herein are to include for delivery to the site, storage, handling, overheads and profit</i>				
22.18	Ordinary Portland Cement	Ton	0		
#REF!	High Yield Steel (any diametre)	Ton	0		
#REF!	Fine Aggregate for Concrete	m3	0		
#REF!	Coarse Aggregate for Concrete	m3	0		
#REF!	Wrot Shuttering Timber	m2	0		
#REF!	Rough shuttering timber.	m2	0		

#REF!	Bitumen Emulsion KI-60.	Litre	0		
#REF!	Straight run bitumen Grade 80/100.	Litre	0		
#REF!	Kerosene	Litre	0		
Bill No. 22 Total Carried Forward to Grand Summary					
BILL NO. 25: ENVIRONMENTAL MITIGATION MEASURES & HIV AIDS CAMPAIGN					
ITEM	DESCRIPTION	UNIT	QTY	RATE	AMOUNT
25.01	All for a prime cost sum for of KShs 50,000 for ESIA study and report, Compliance Audits and environmental monitoring.	PC sum	0		
25.02	E.O for Item 25.01 for Contractor's Oveheads and Profit	Item	%		
25.03	Allow for engagement of a HIV/AIDS specialist subcontractor to deal with prevention, awareness activities as per programme to be approved by the Engineer	Item	0		
25.05	Allow for preparation and submmision of monthly reports on HIV/AIDS awareness and prevention activities. Report to be tabled at site meetings.	Months	0		
25.08	Allow for production and distribution of HIV/AIDS awareness material as follows:				
	a) T-Shirt printed with approved message and graphics	No.	0		
	b) Ditto (a) above but caps	No.	0		
	e) 200x150mm stickers with HIV/AIDS awareness/prevention slogan	No.	0		
Bill No. 25 Total Carried Forward to Grand Summary					
SUMMARY OF BILL OF QUANTITIES					

BILL ITEM	DESCRIPTION	AMOUNT (KSHS)			
1	Preliminaries and General Items				
4	Site Clearance and Top Soil Stripping				
5	Earth Works				
7	Excavation and Filling of Structures				
8	Culverts and Drainage Works				
9	Passage to Traffic				
12	Natural Gravel Base and Subbase				
14	Lime/Cement Improved gravel Subbase and Base				
15	Bituminous Surface Treatment and Surface Dressing				
16	Bituminous Mixes				
20	Road Furniture				
22	Schedule of Dayworks.				
25	HIV/AIDS, Gender & Social Issues, Local Participation	item	1	50,000	
(A)	SUB-TOTAL (1)				
(C)	Add 5% CONTIGENCIES of sub total (1)				
(D)	SUB-TOTAL (2) = (A + B + C)				
(E)	Add ...16% VAT of sub-total (2)				

TOTAL CARRIED FORWARD TO FORM OF BID AS BID SUM 1				

DRAWINGS

FIGURE C.1 - CULVERT ENTRY / EXIT STRUCTURE TYPES

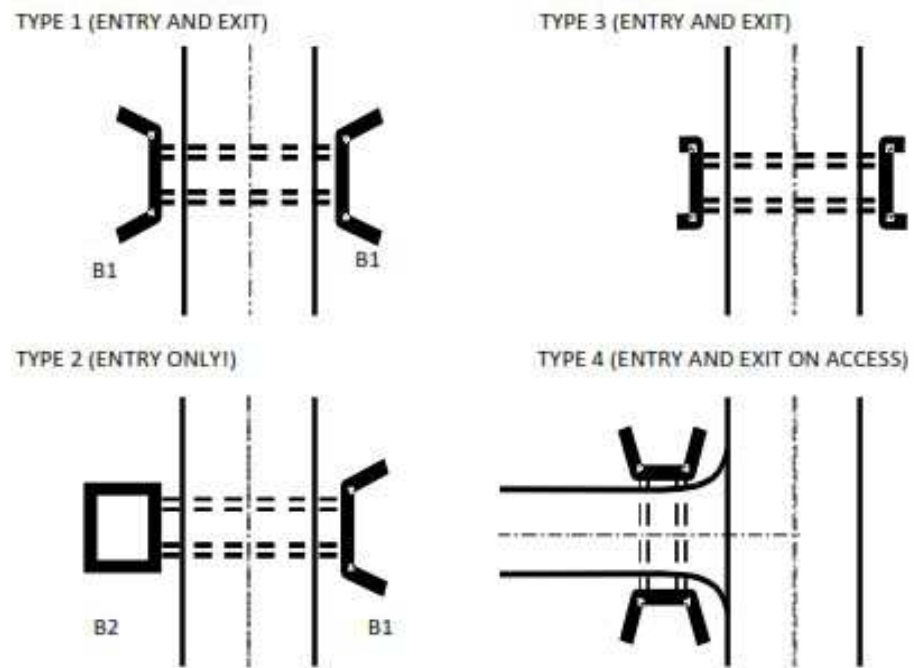

NOTE:

Coding system has been used in describing the standardised designs of the various culvert entry and exit structures. The code names consist of a number

to specify shape and function as elaborated in above while the used construction materials are identified through an alphabetic symbol as follows:

- A = Concrete block
- B = Stone masonry
- C = Dressed stones

An example code of "B2" would therefore stand for a drop inlet type structure to be built in stone masonry.

**FIGURE C.2 -
HEADWALL TYPE 1
(HEAD AND
WINGWALLS)**

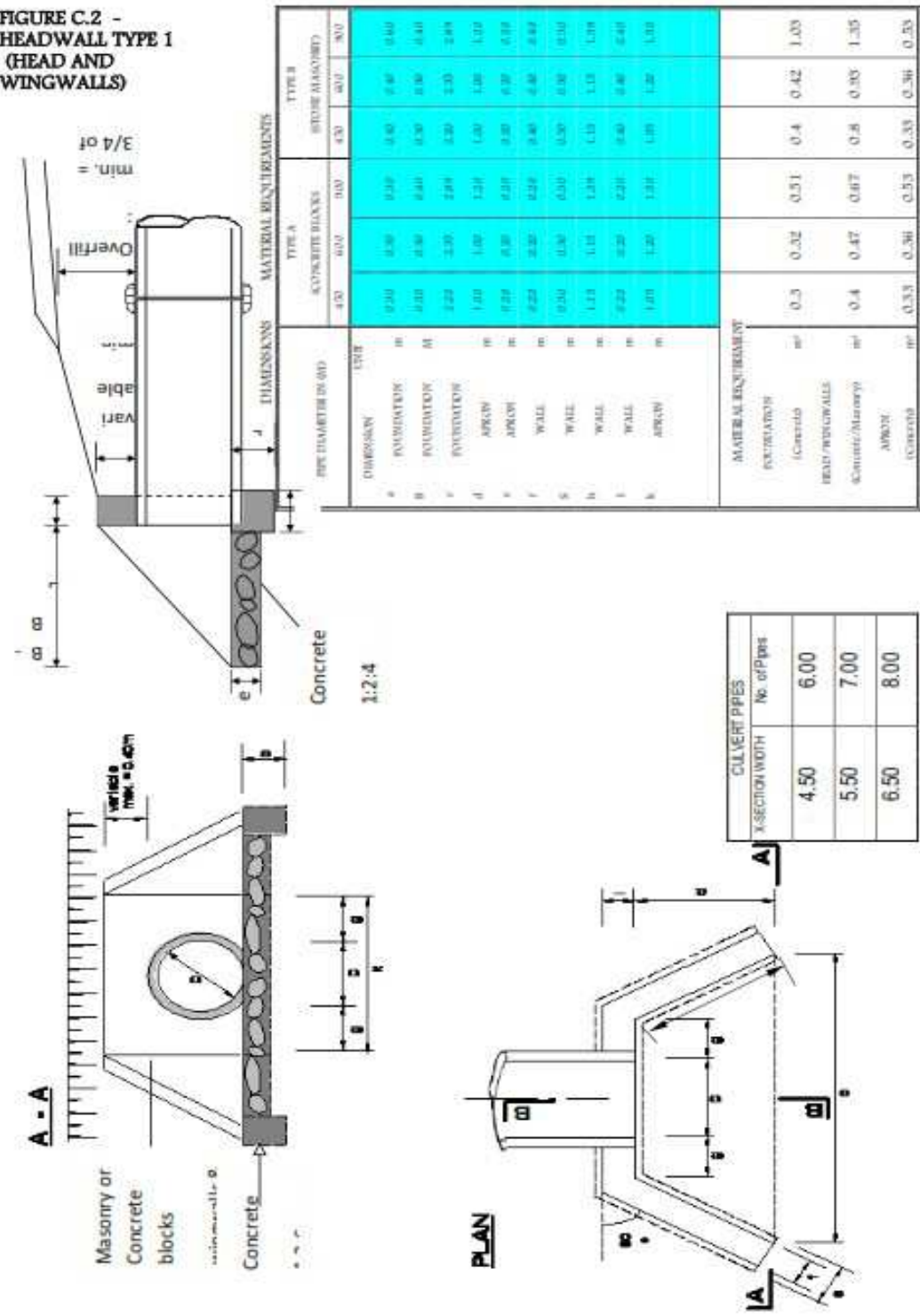

FIGURE C.3 - HEADWALL TYPE 2 (DROP INLET)

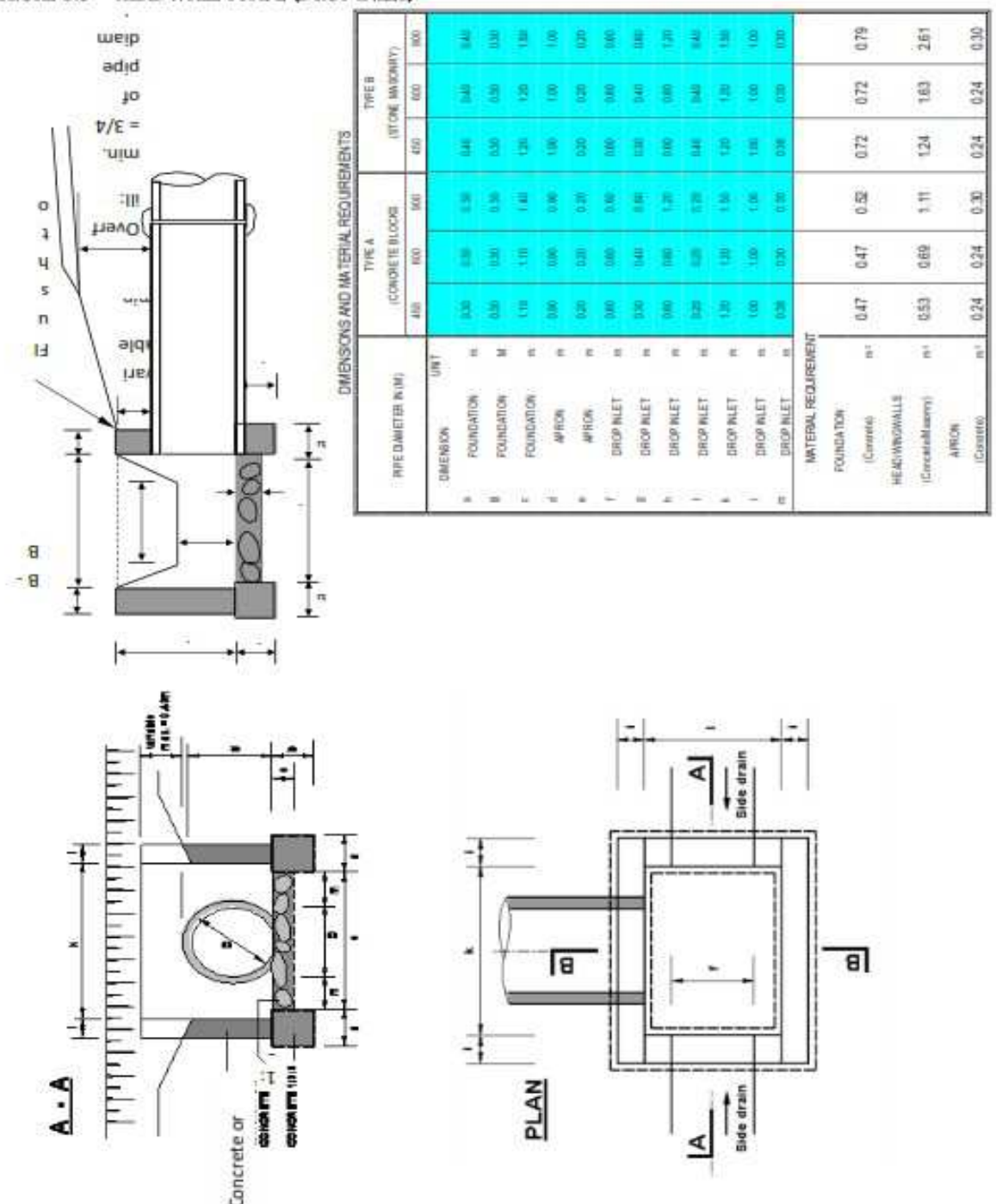

FIGURE C.4 - HEADWALL TYPE 3A (CONCRETE BLOCK HEADWALLS)

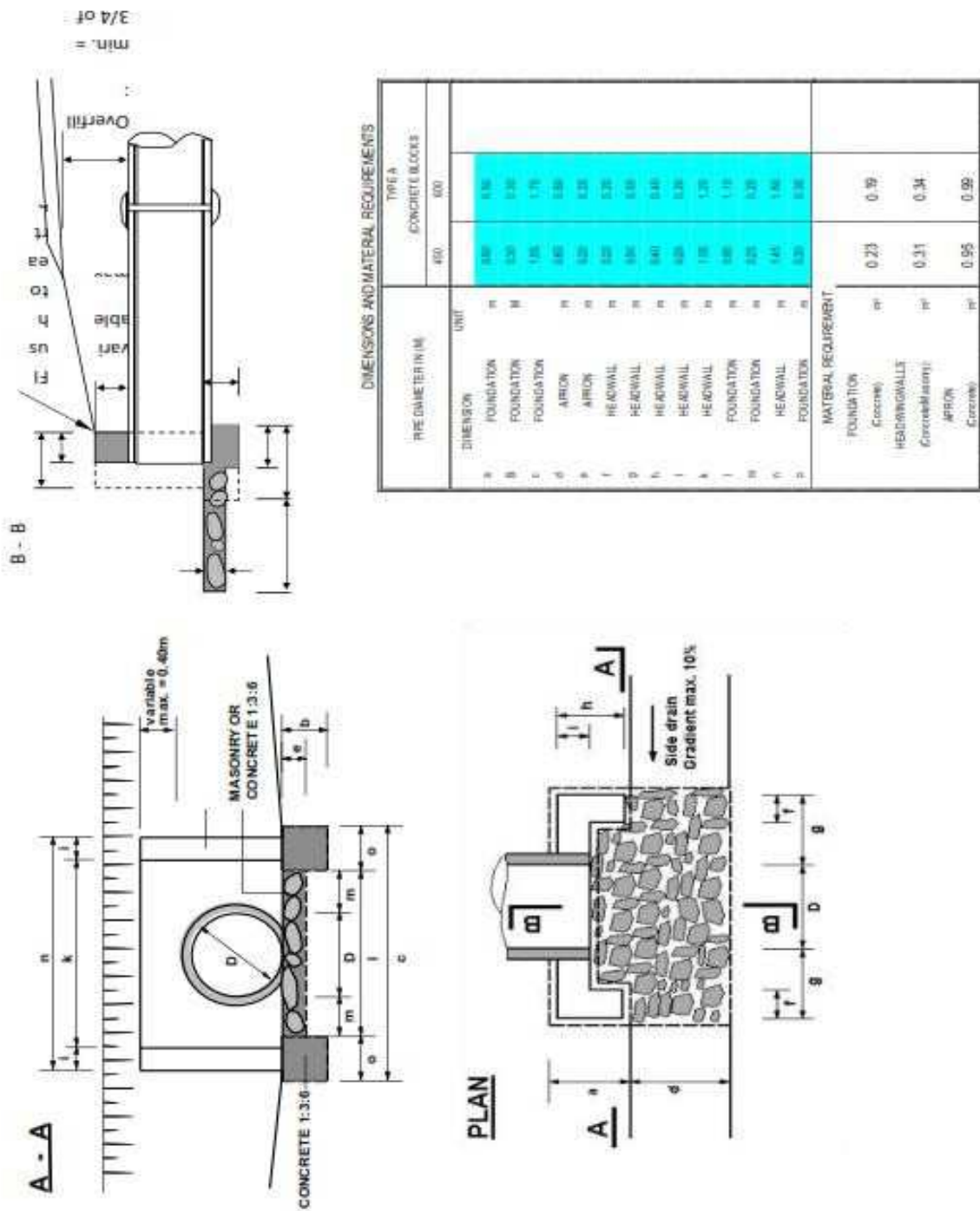

FIGURE C.5 - HEADWALL TYPE 3B (STONE MASONRY HEADWALLS)

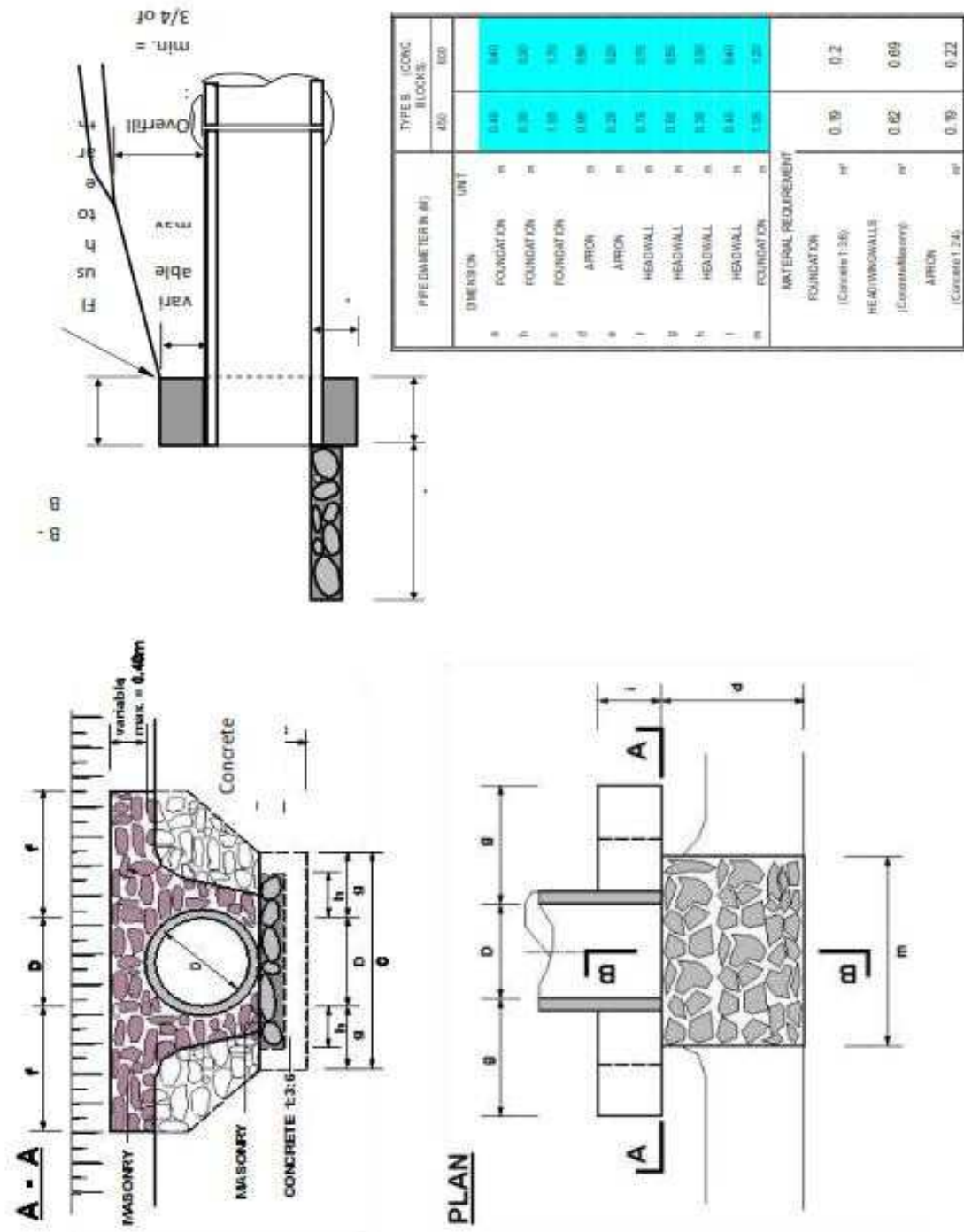

FIGURE C.6 - HEADWALL TYPE 4 (FOR ACCESS CULVERTS)

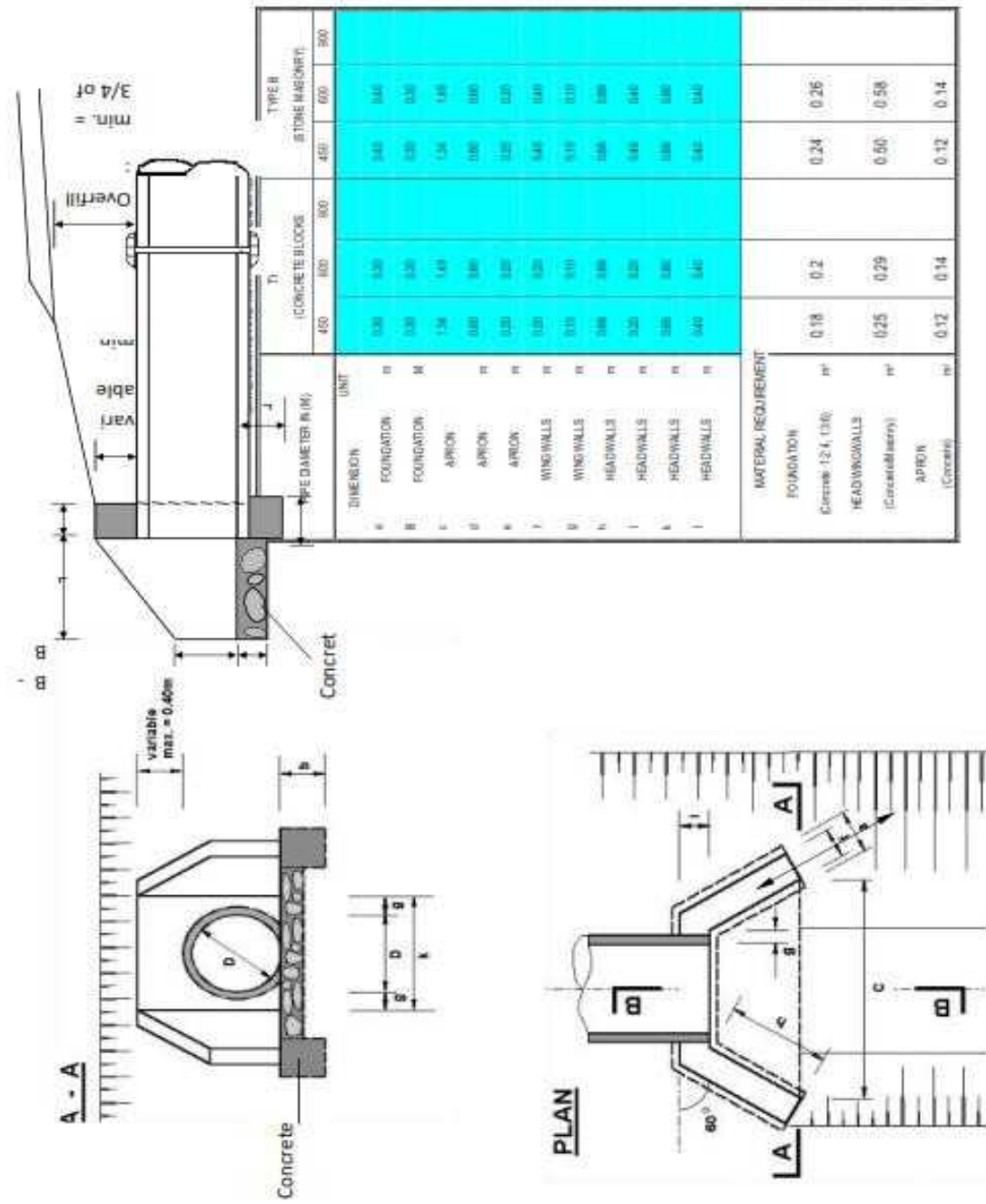
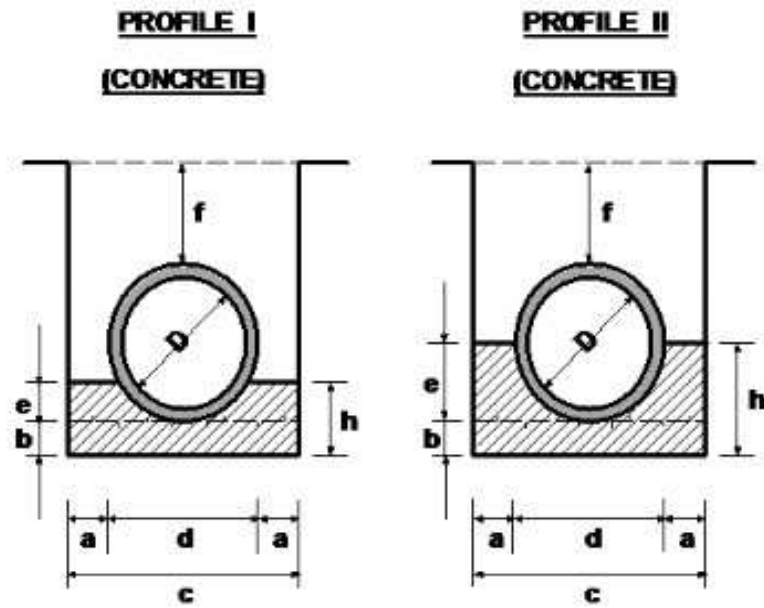

FIGURE C.7- BEDDING AND HAUNCH PROFILES TYPES I & II



Diameter (D)	450 (mm)	600 (mm)	900 (mm)
Dimensions in (m)			
a	0.15	0.2	0.2
b	0.1	0.15	0.15
c	0.86	1.12	1.48
d	0.56	0.72	1.08
e	0.14	0.18	0.27
f (min.)	0.34	0.45	0.68
g	-	-	-
h	0.24	0.33	0.42
i	-	-	-
Concrete	Volume in (m ³ /m)		
	0.16	0.3	0.48
Application	- Fair subgrade condition; - Overfill > ¼ Diameter; - Seasonal waterflow only.		
Remarks	- Use gravel material for back/ overfill.		

450 (mm)	600 (mm)	900 (mm)
Dimensions in (m)		
0.15	0.2	0.2
0.1	0.15	0.15
0.86	1.12	1.48
0.56	0.72	1.08
0.28	0.36	0.54
0.34	0.45	0.68
-	-	-
0.38	0.51	0.69
-	-	-
Volume in (m ³ /m)		
0.2	0.37	0.56
- Fair to poor subgrade Condition; - Overfill > ¼ Diameter; - Seasonal waterflow only.		
- Use gravel material for back/ overfill.		

FIGURE C.8 - BEDDING AND HAUNCH PROFILES TYPES III & IV

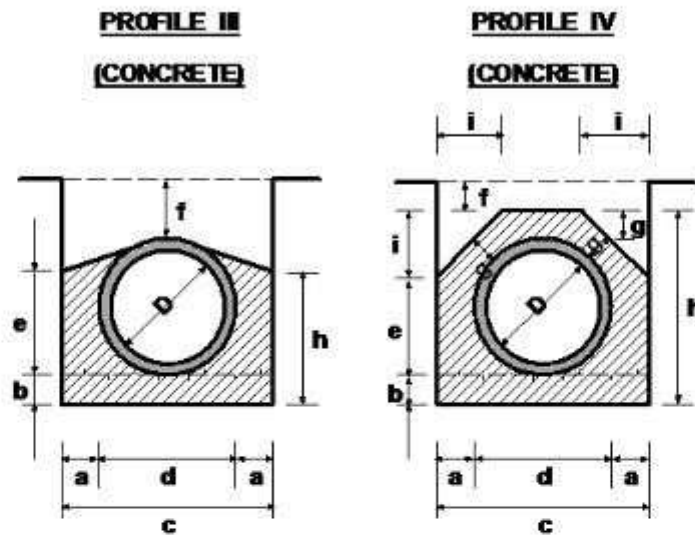

Diameter (D)	450 (mm)	600 (mm)	900 (mm)
Dimensions in (m)			
a	0.15	0.2	0.2
b	0.1	0.15	0.15
c	0.86	1.12	1.48
d	0.56	0.72	1.08
e	0.42	0.54	0.81
f (min.)	0.23	0.3	0.45
g	-	-	-
h	0.52	0.69	0.96
i	-	-	-
Concrete	Volume in (m ³ /m)		
	0.26	0.47	0.71
Application	- Fair subgrade condition; - Overfill > ¼ Diameter; - Seasonal waterflow only.		
Remarks	- Use gravel material for back/overfill.		

	450 (mm)	600 (mm)	900 (mm)
Dimensions in (m)			
	0.15	0.2	0.2
	0.1	0.15	0.15
	0.86	1.12	1.48
	0.56	0.72	1.08
	0.46	0.52	0.78
	0.15	0.15	0.15
	0.15	0.15	0.15
	0.81	1.02	1.38
	0.28	0.35	0.45
	Volume in (m ³ /m)		
	0.37	0.61	0.92
	- Fair to poor subgrade Condition; - Overfill > ¼ Diameter; - Seasonal waterflow only.		
	- Use gravel material for back/overfill.		

FIGURE C.8 - BEDDING AND HAUNCH PROFILES TYPES III & IV

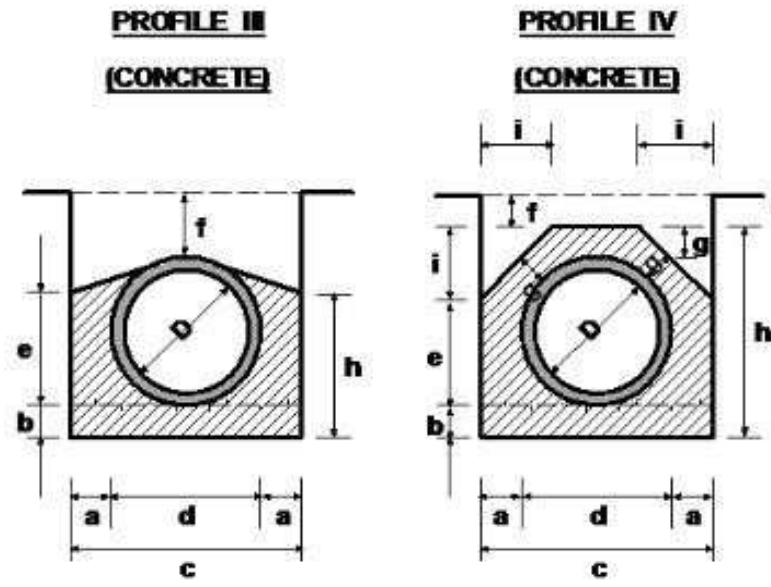

Diameter (D)	450 (mm)	600 (mm)	900 (mm)
Dimensions in (m)			
a	0.15	0.2	0.2
b	0.1	0.15	0.15
c	0.86	1.12	1.48
d	0.56	0.72	1.08
e	0.42	0.54	0.81
f (min.)	0.23	0.3	0.45
g	-	-	-
h	0.52	0.69	0.96
i	-	-	-
Concrete	Volume in (m ³ /m)		
	0.26	0.47	0.71
Application	- Fair subgrade condition; - Overfill > ¼ Diameter; - Seasonal waterflow only.		
Remarks	- Use gravel material for back/overfill.		

	450 (mm)	600 (mm)	900 (mm)
Dimensions in (m)			
	0.15	0.2	0.2
	0.1	0.15	0.15
	0.86	1.12	1.48
	0.56	0.72	1.08
	0.46	0.52	0.78
	0.15	0.15	0.15
	0.15	0.15	0.15
	0.81	1.02	1.38
	0.28	0.35	0.45
	Volume in (m ³ /m)		
	0.37	0.61	0.92
	- Fair to poor subgrade Condition; - Overfill > ¼ Diameter; - Seasonal waterflow only.		
	- Use gravel material for back/overfill.		

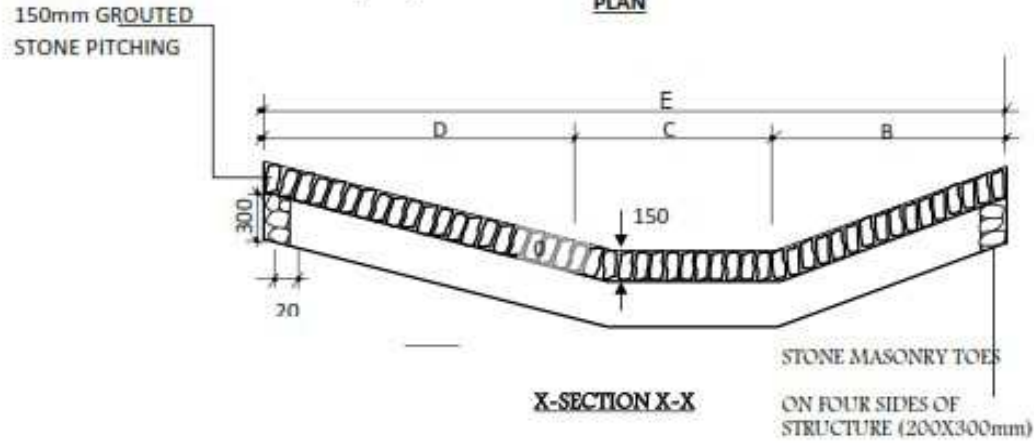
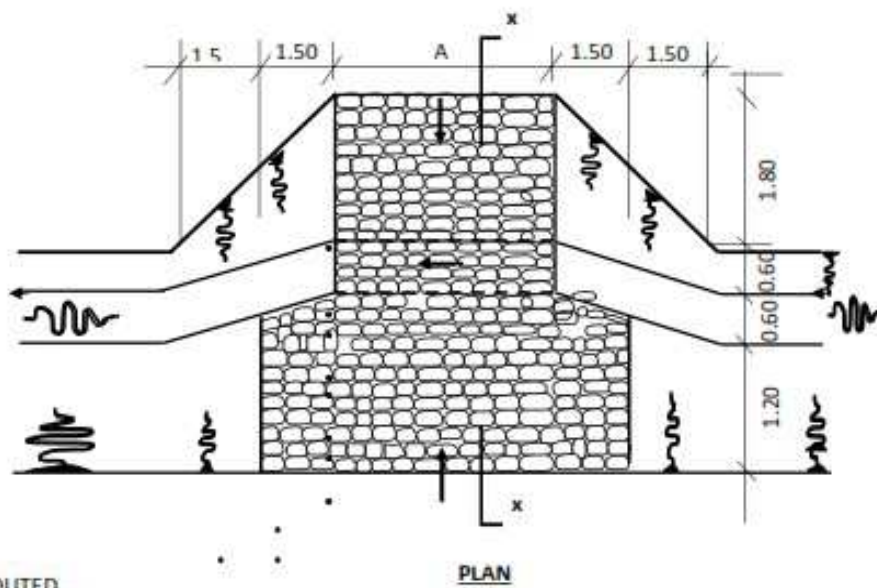

QUANTITIES TABLE								
Cross section	DIMENSIONS					RED	Stone masonry (m ³)	150mm Grouted stone pitching (m ³)
	A	B	C	D	E	Excavation (m ³)		
	A	4000	1800	600	1800			
	8000	1800	600	1800	4200	10.00	1.60	30.15
B	4000	1400	400	1800	3600	7.00	1.20	18.30
	8000	1400	400	1800	3600	9.00	1.50	25.50

